

US008895974B2

(12) **United States Patent**
Sugimoto et al.

(10) **Patent No.:** **US 8,895,974 B2**
(45) **Date of Patent:** **Nov. 25, 2014**

(54) **ORGANIC EL DISPLAY DEVICE AND METHOD FOR MANUFACTURING THE SAME**

(58) **Field of Classification Search**
CPC H01L 51/52; H01L 51/56; H01L 27/32
USPC 257/40, 72, 79, 89, 88; 438/149, 29; 313/500-506
See application file for complete search history.

(75) Inventors: **Hiroshi Sugimoto**, Osaka (JP); **Tohru Sonoda**, Osaka (JP)

(56) **References Cited**

(73) Assignee: **Sharp Kabushiki Kaisha**, Osaka (JP)

U.S. PATENT DOCUMENTS

(*) Notice: Subject to any disclaimer, the term of this patent is extended or adjusted under 35 U.S.C. 154(b) by 0 days.

2002/0014628 A1* 2/2002 Koyama 257/72
2005/0062407 A1* 3/2005 Suh et al. 313/504
(Continued)

(21) Appl. No.: **13/980,310**

FOREIGN PATENT DOCUMENTS

(22) PCT Filed: **Jan. 31, 2012**

JP 2005-340202 A 12/2005
JP 2006-140127 A 6/2006
JP 2007-73249 A 3/2007

(86) PCT No.: **PCT/JP2012/000603**

§ 371 (c)(1),
(2), (4) Date: **Jul. 17, 2013**

OTHER PUBLICATIONS

(87) PCT Pub. No.: **WO2012/108142**

International Search Report received for PCT Patent Application No. PCT/JP2012/000603 mailed on May 1, 2012, 5 pages (2 pages of English Translation and 3 pages of ISR).

PCT Pub. Date: **Aug. 16, 2012**

Primary Examiner — Chuong A Luu

Assistant Examiner — Sheikh Maruf

(65) **Prior Publication Data**

US 2013/0299808 A1 Nov. 14, 2013

(74) *Attorney, Agent, or Firm* — Morrison & Foerster LLP

(30) **Foreign Application Priority Data**

Feb. 7, 2011 (JP) 2011-023987

(57) **ABSTRACT**

(51) **Int. Cl.**

H01L 29/08 (2006.01)
H01L 21/00 (2006.01)
H01L 51/56 (2006.01)
H01L 27/32 (2006.01)
H01L 51/52 (2006.01)

In an organic EL display device (100), an insulating layer (113) includes a first insulating film (113a) and a second insulating film (113b) provided thereabove, a plurality of upper electrodes (115c) are each provided to cover a corresponding one of a plurality of organic EL layers (115b), and a reflection film (114) is provided between the first insulating film (113a) and the second insulating film (113b), corresponding to a region N other than the a light emission region. The reflection film (114) reflects toward a sealing substrate (120) a portion of light generated in each organic EL layer (115b) which is diffused into the region N other than the light emission region so that the portion of the light is transmitted through a separation wall portion (116) and the sealing substrate (120) to be viewed as an image on the sealing substrate.

(52) **U.S. Cl.**

CPC **H01L 51/5203** (2013.01); **H01L 51/56** (2013.01); **H01L 27/3258** (2013.01); **H01L 51/5271** (2013.01); **H01L 2251/5323** (2013.01)
USPC **257/40**; **438/82**

17 Claims, 40 Drawing Sheets

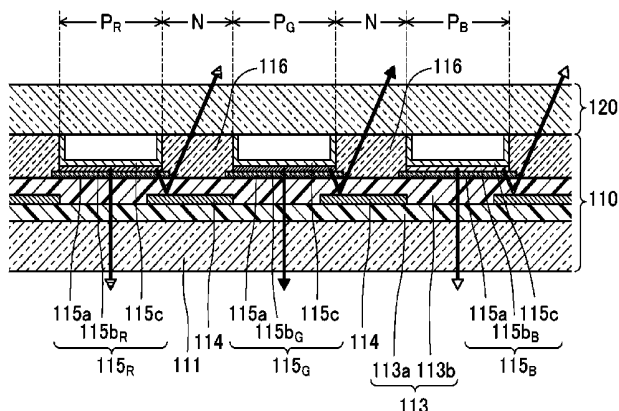

(56)

References Cited

U.S. PATENT DOCUMENTS

2005/0093434	A1 *	5/2005	Suh et al.	313/504	2005/0258740	A1	11/2005	Kim	
2005/0093435	A1 *	5/2005	Suh et al.	313/504	2006/0097251	A1 *	5/2006	Kang 257/40
2005/0151830	A1 *	7/2005	Yamazaki	347/238	2006/0097631	A1 *	5/2006	Lee 313/504
						2008/0081105	A1 *	4/2008	Suh et al. 427/58
						2009/0073093	A1 *	3/2009	Yamazaki 345/76

* cited by examiner

FIG. 1

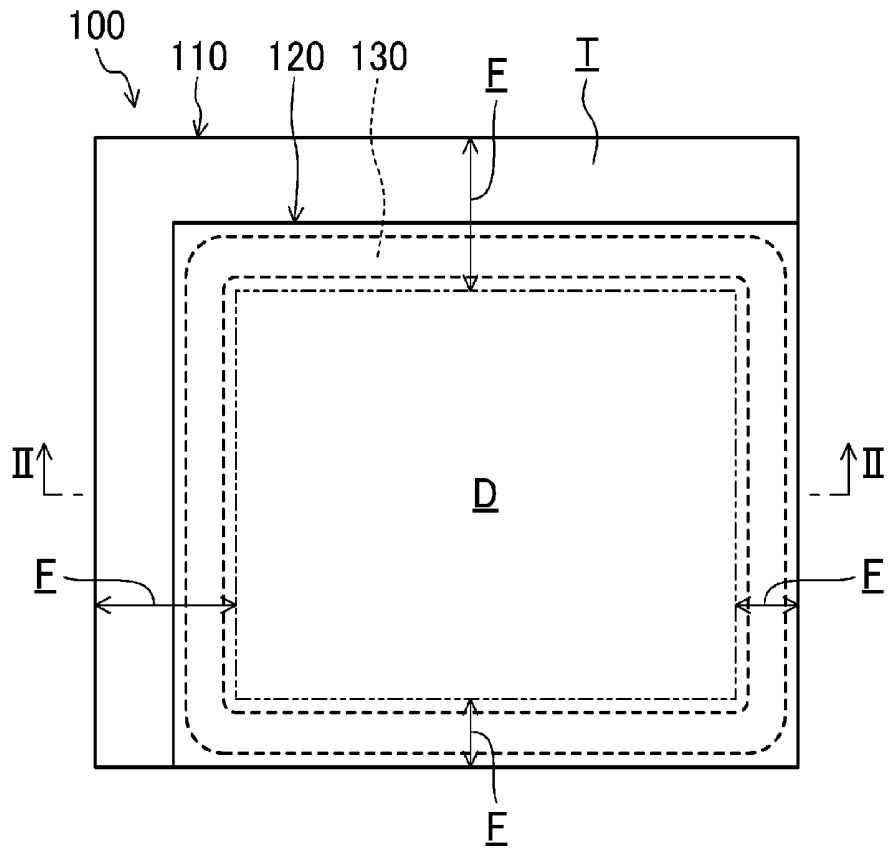

FIG. 2

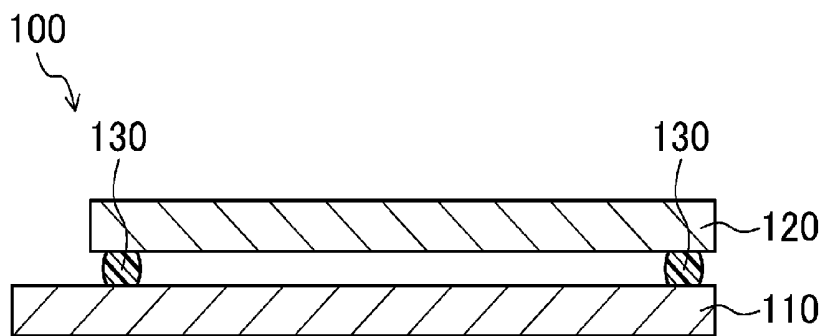
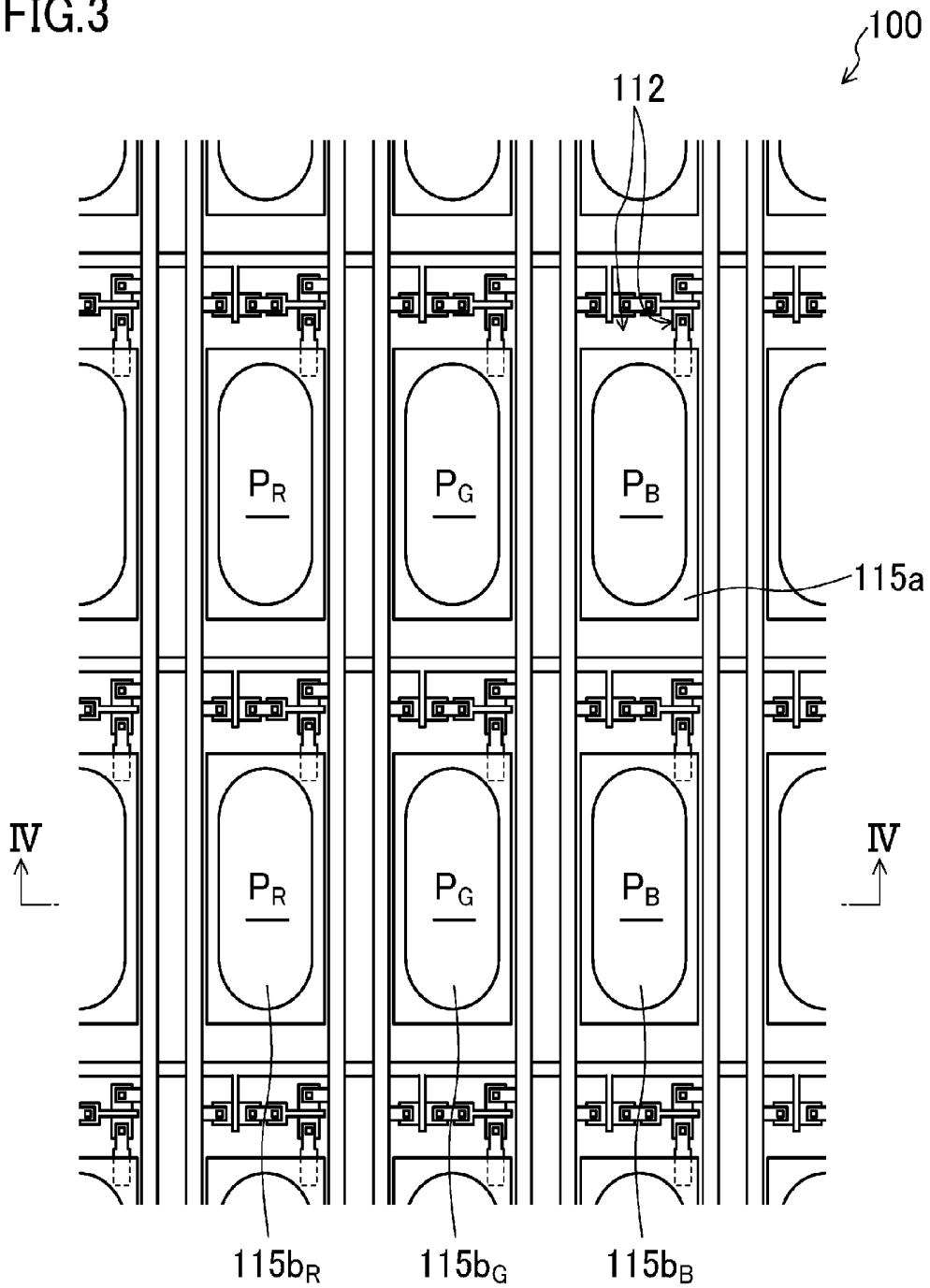

FIG. 3



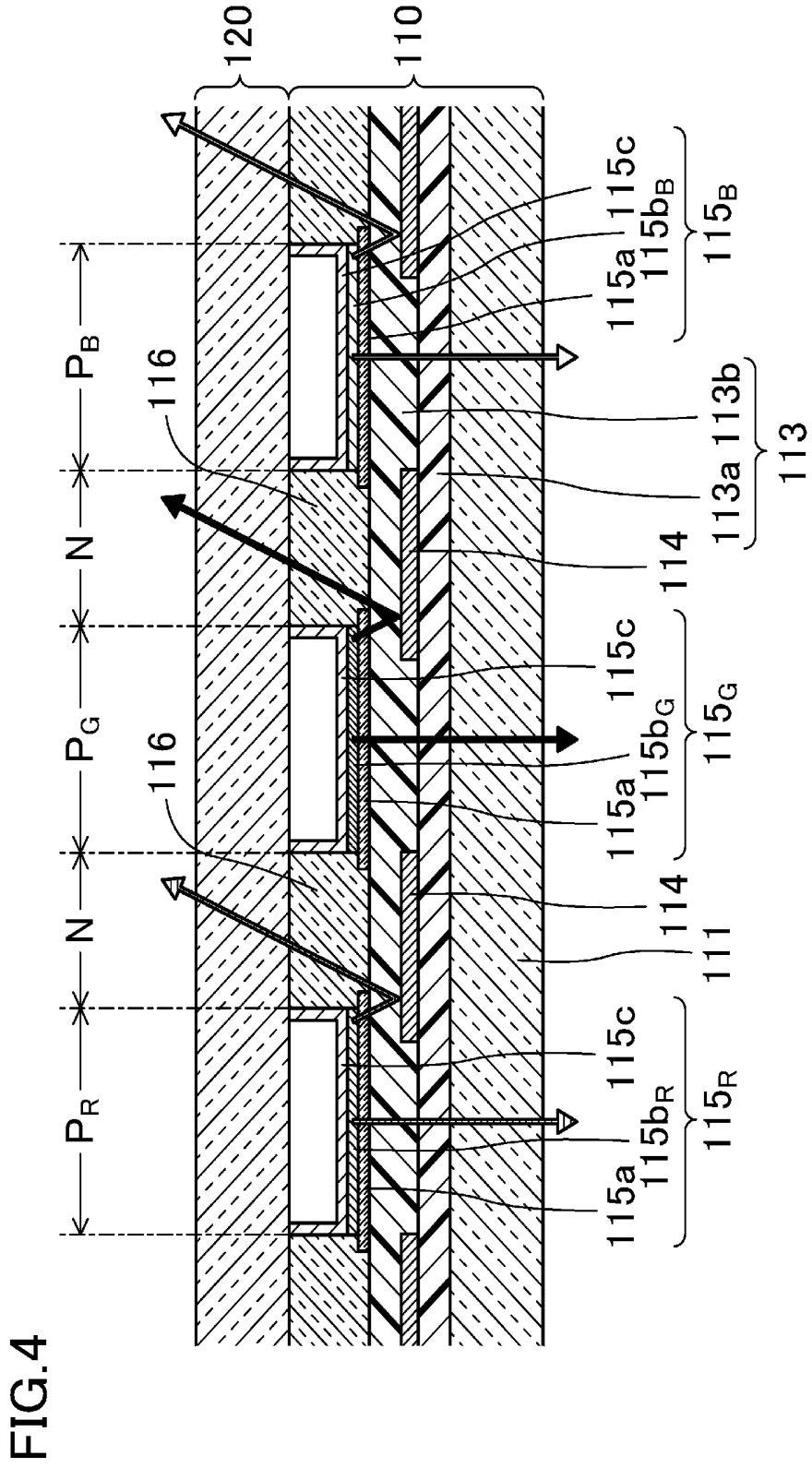

FIG.5

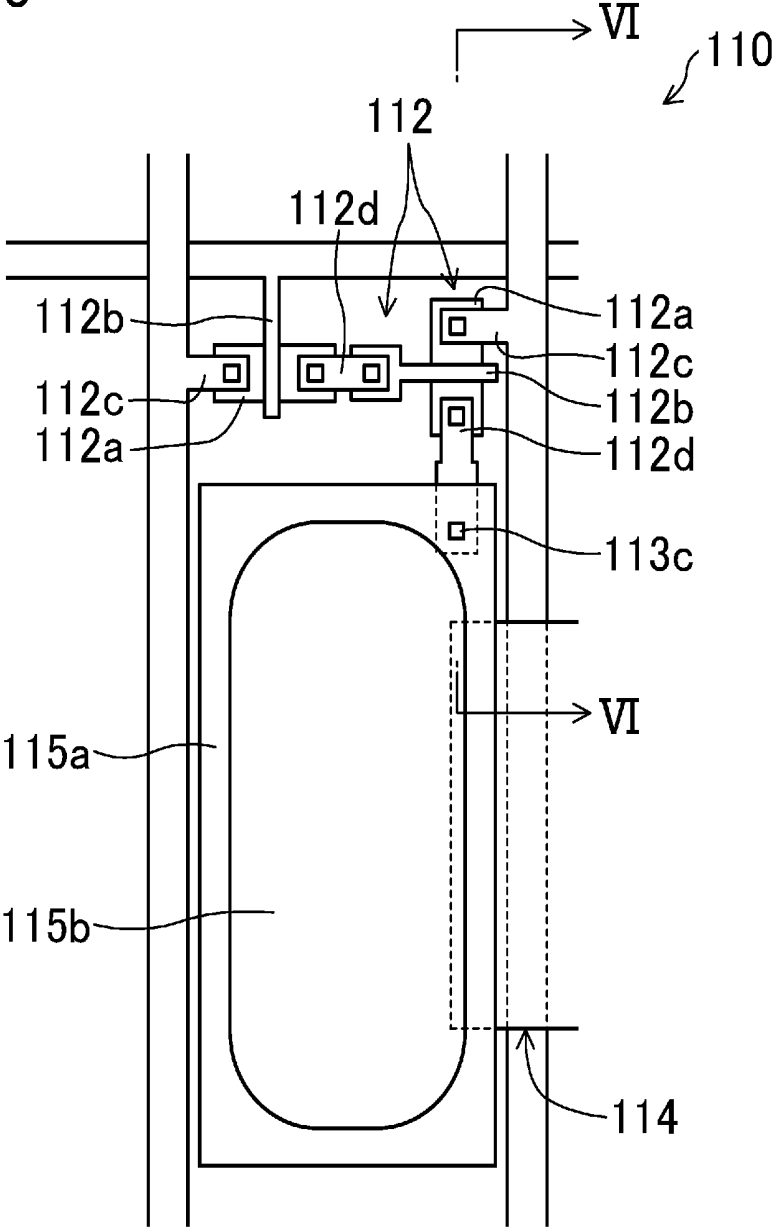

FIG. 6

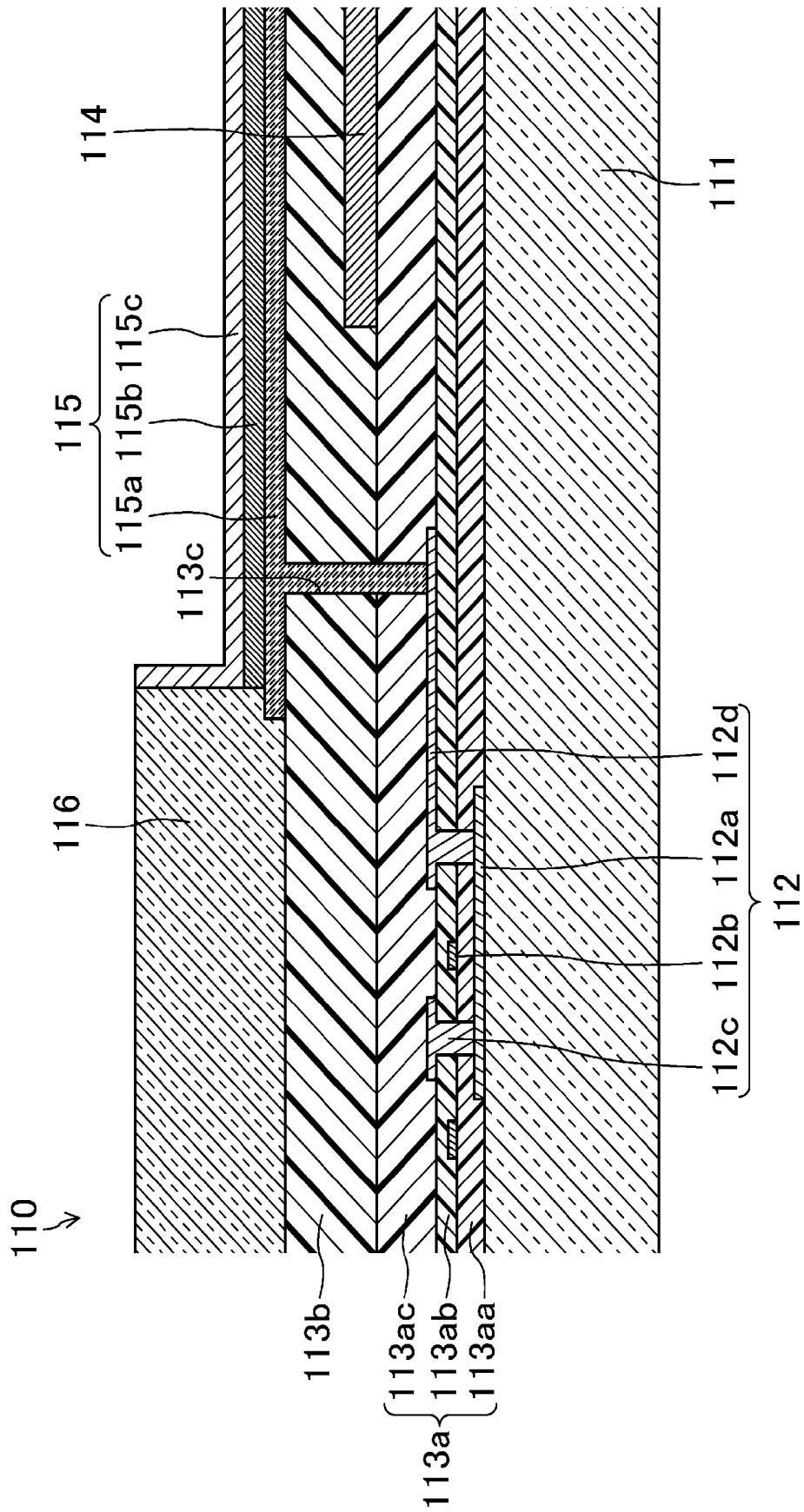

FIG. 7

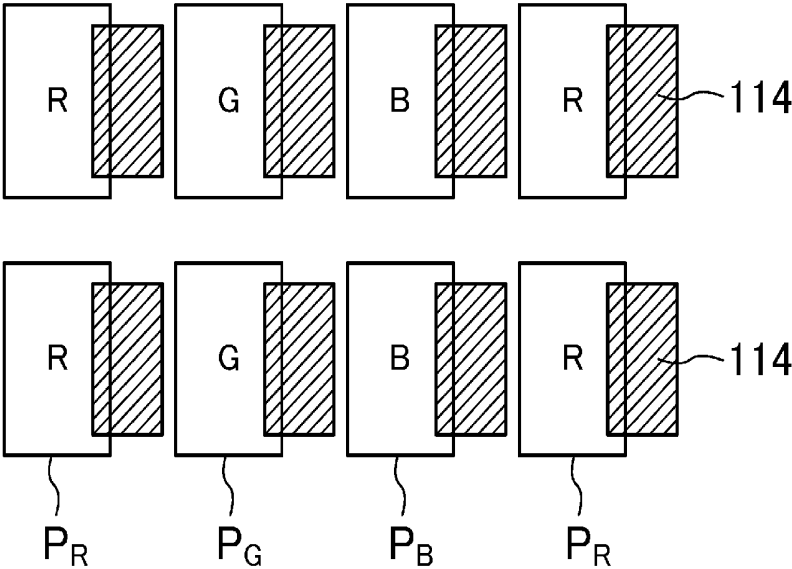

FIG.8

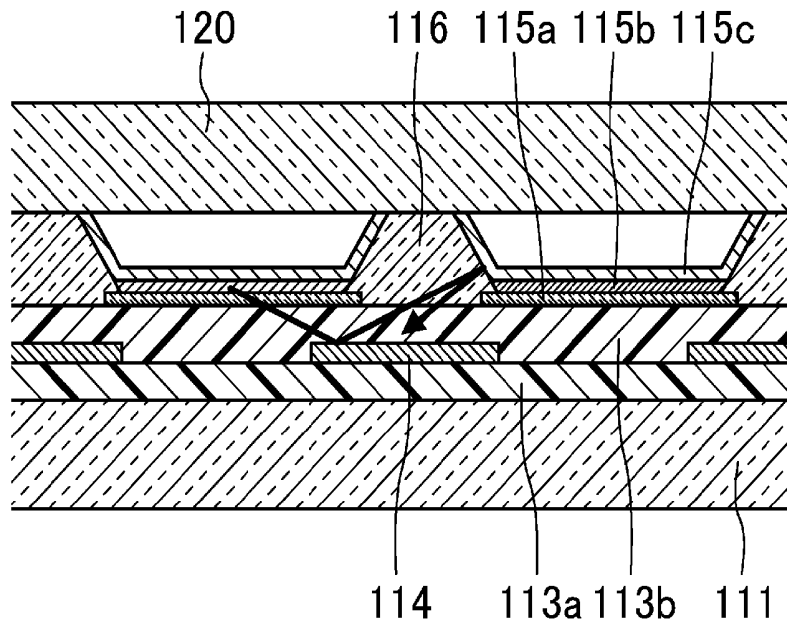

FIG.9

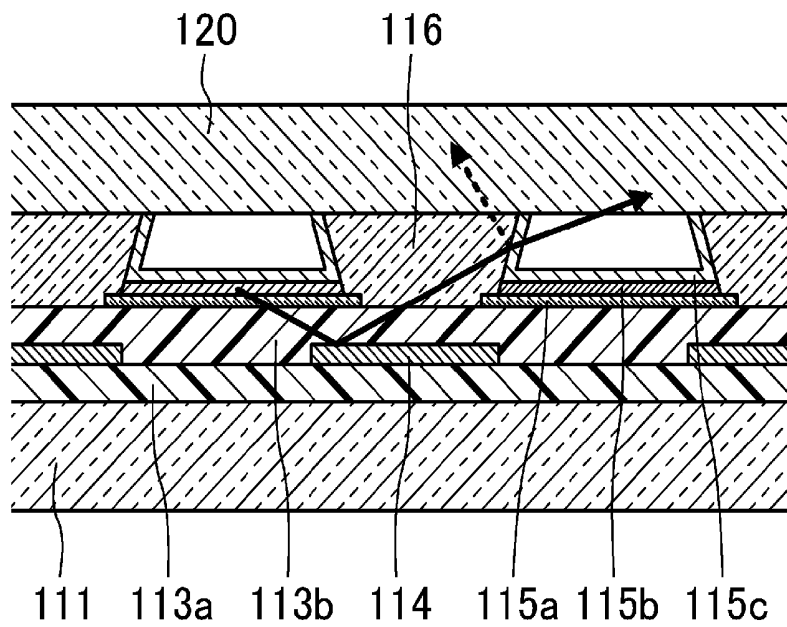

FIG.10A

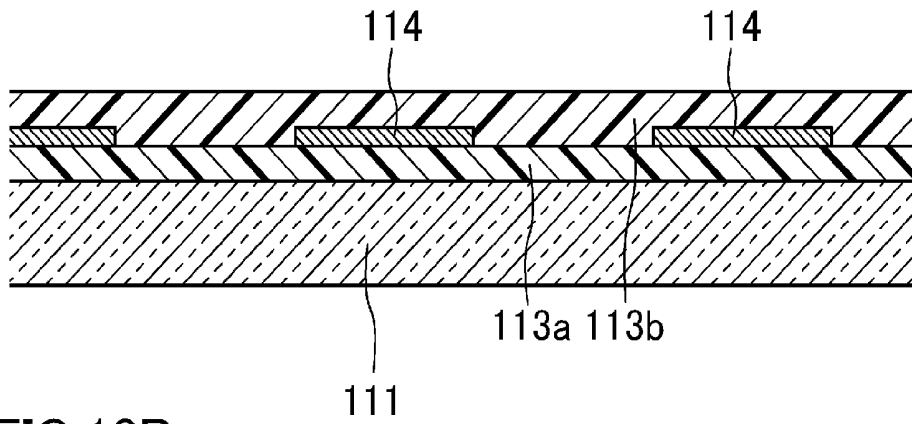

FIG.10B

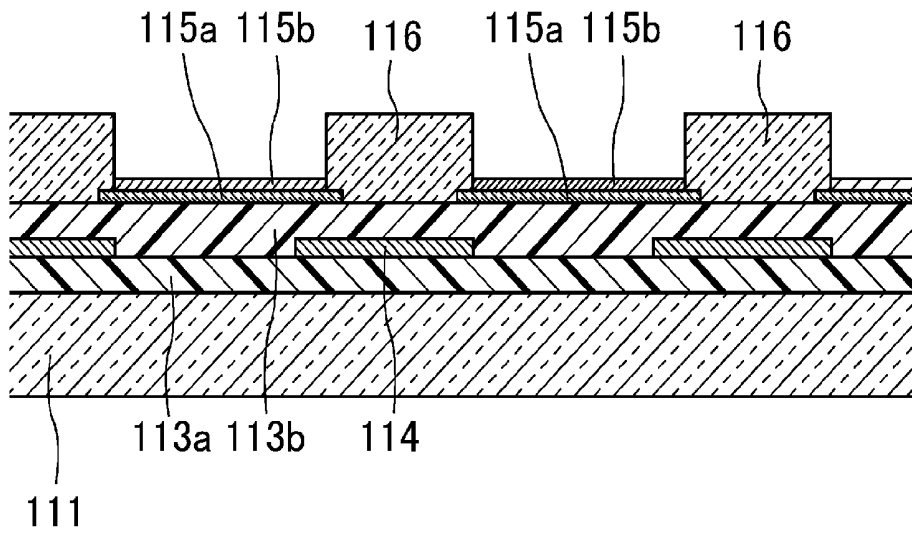

FIG.10C

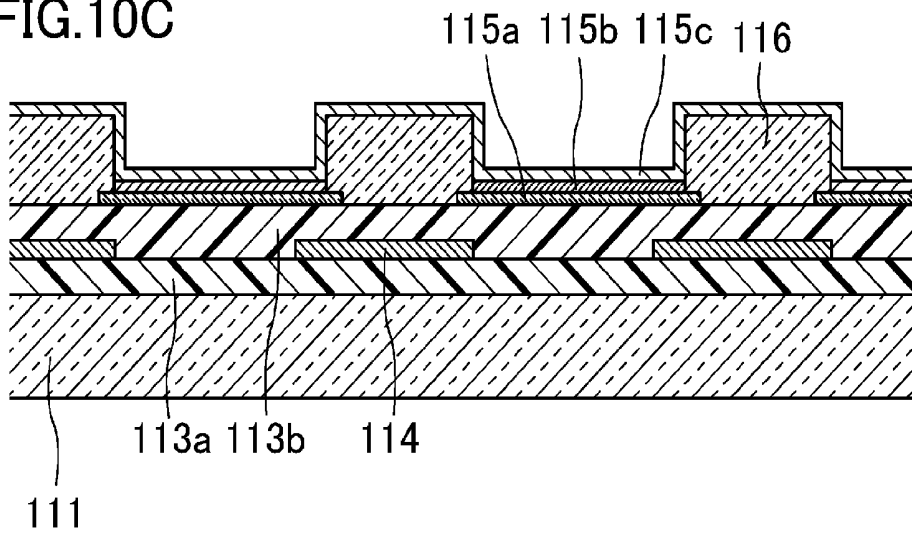

FIG.11A

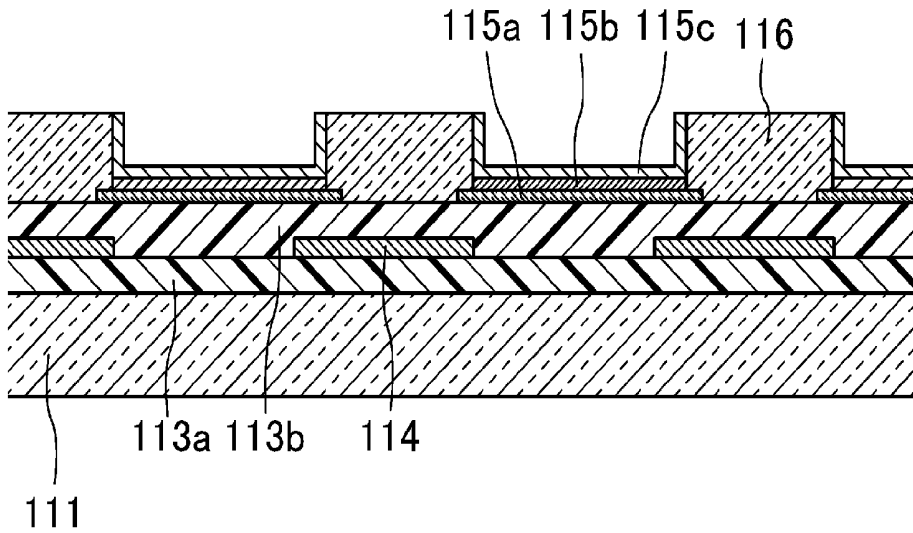

FIG.11B

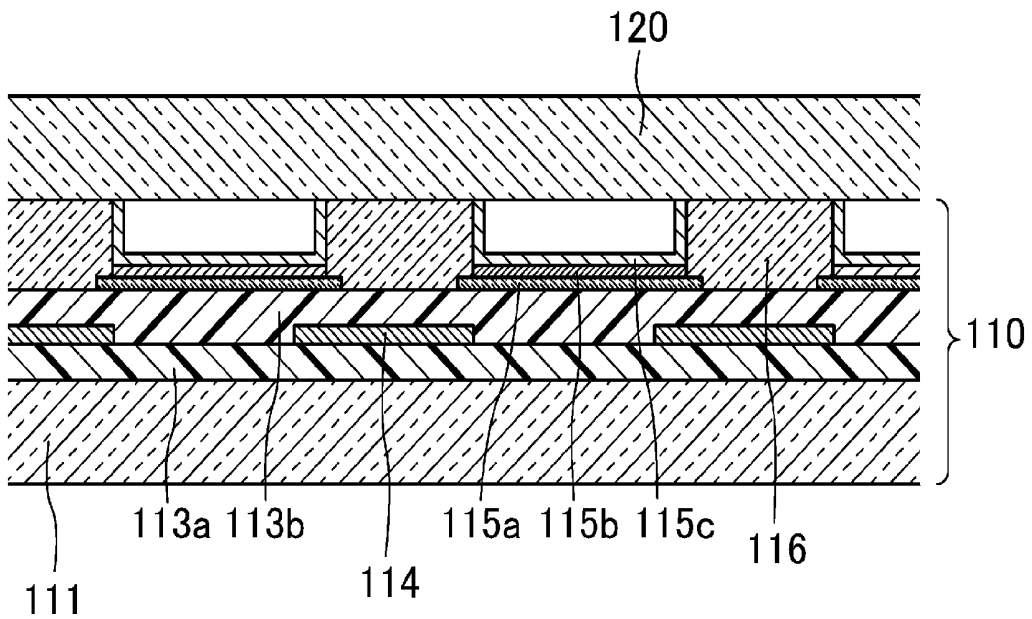

FIG.12

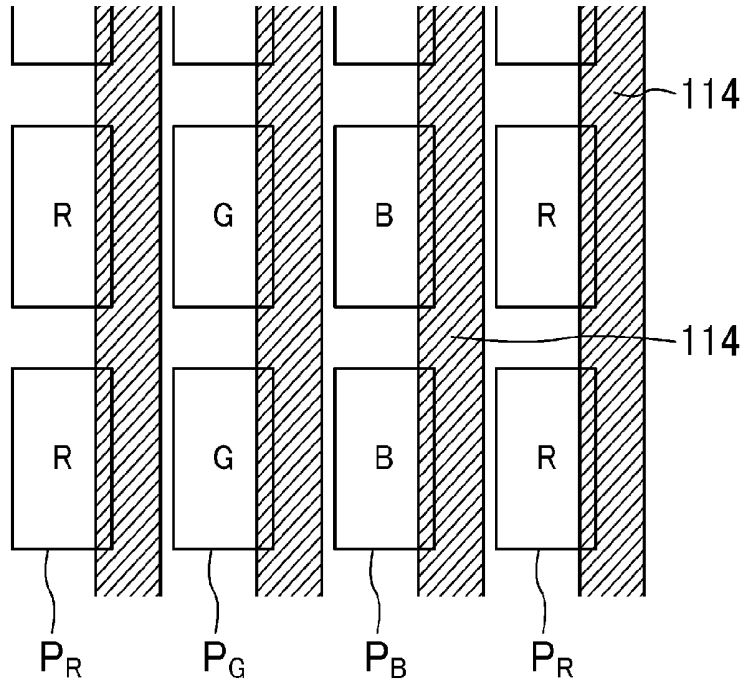

FIG.13

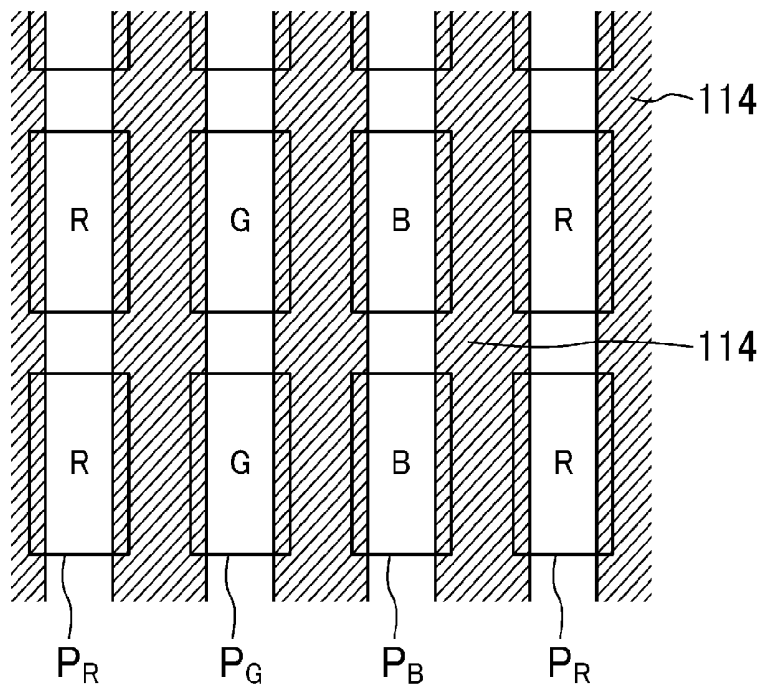

FIG.14

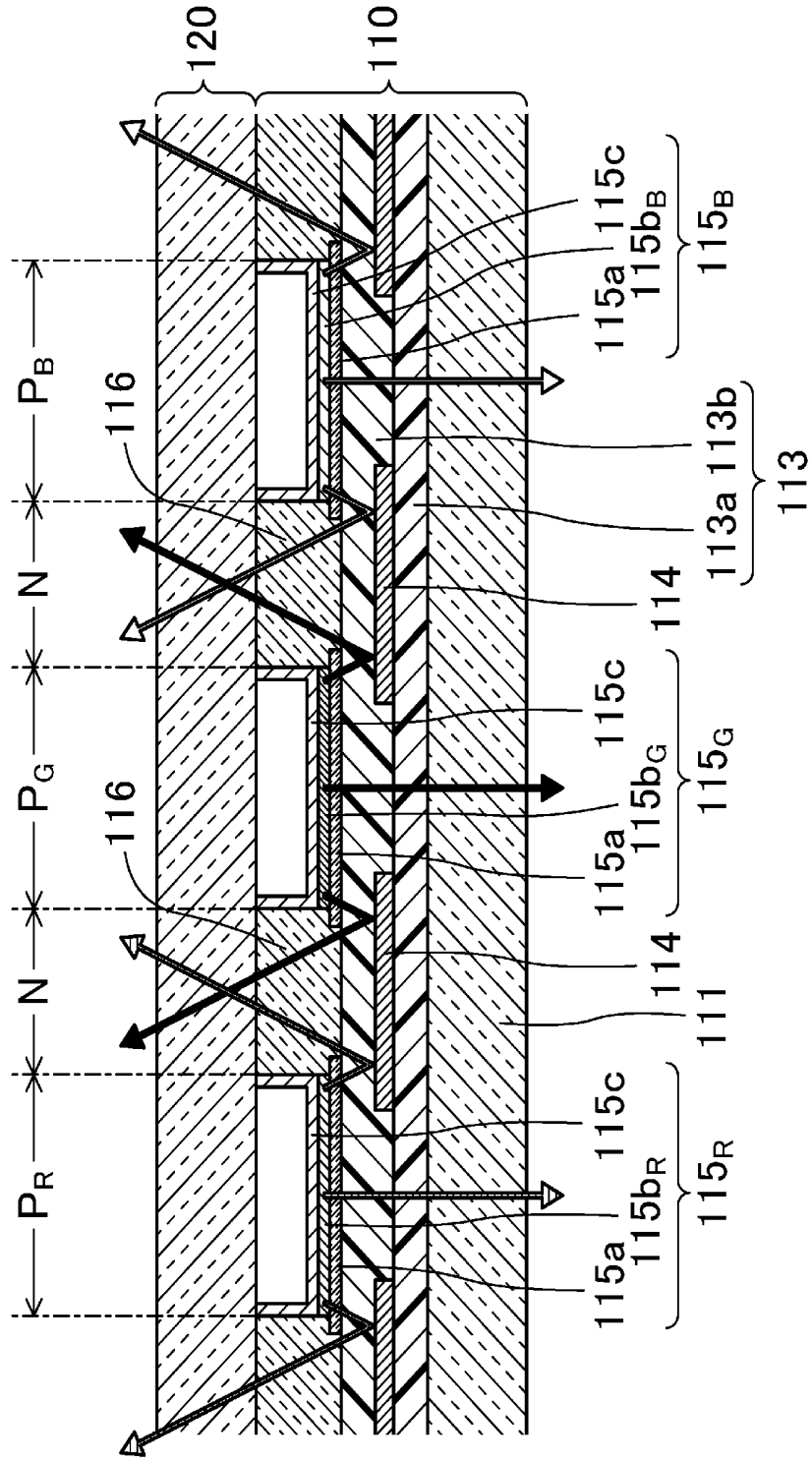

FIG. 15

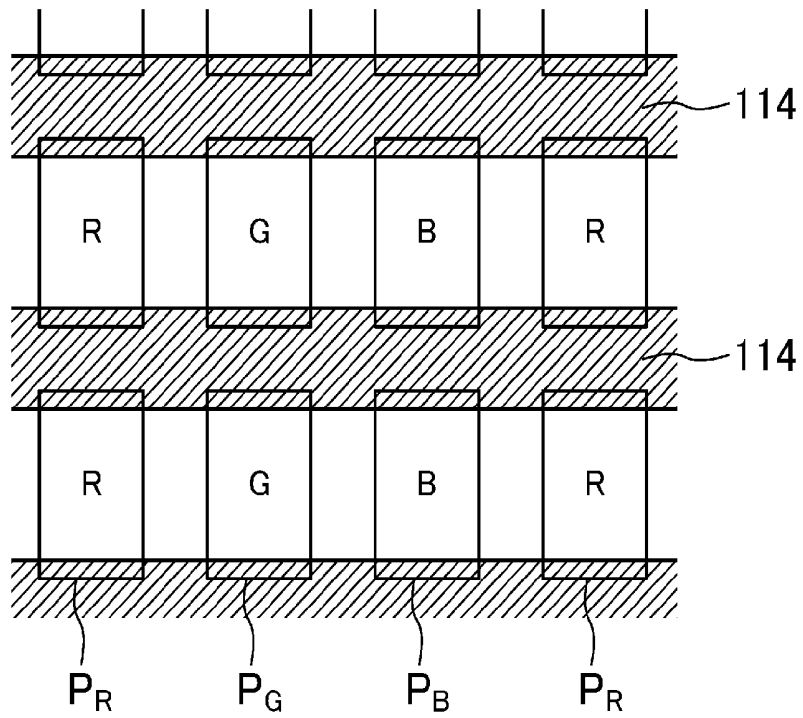

FIG. 16

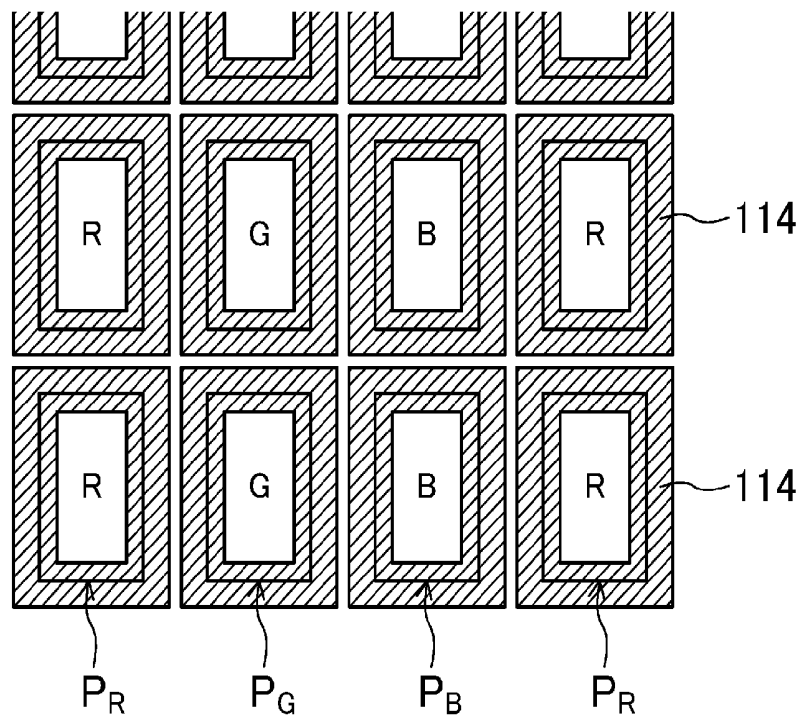

FIG.17

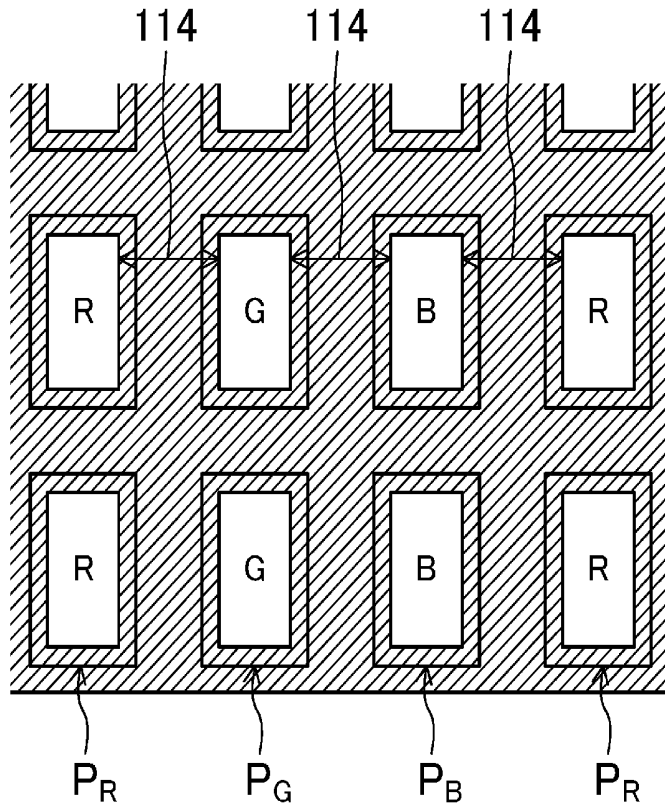

FIG.18

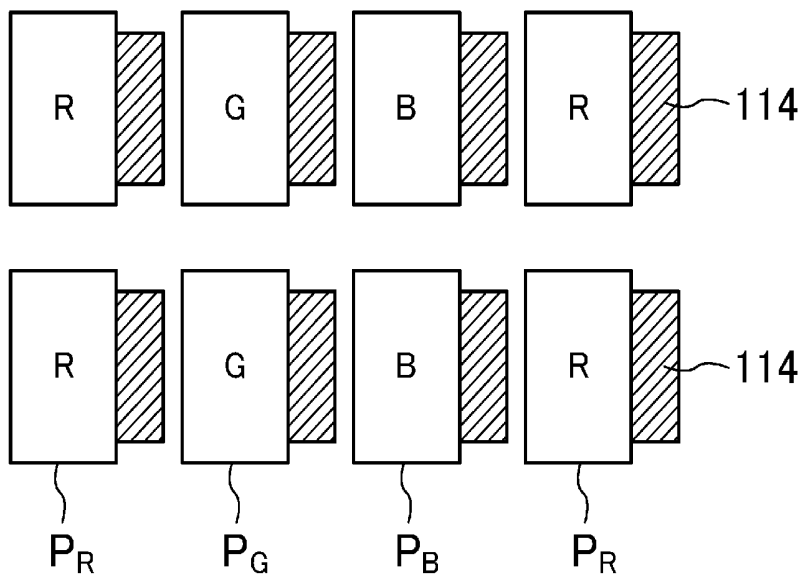

FIG. 19

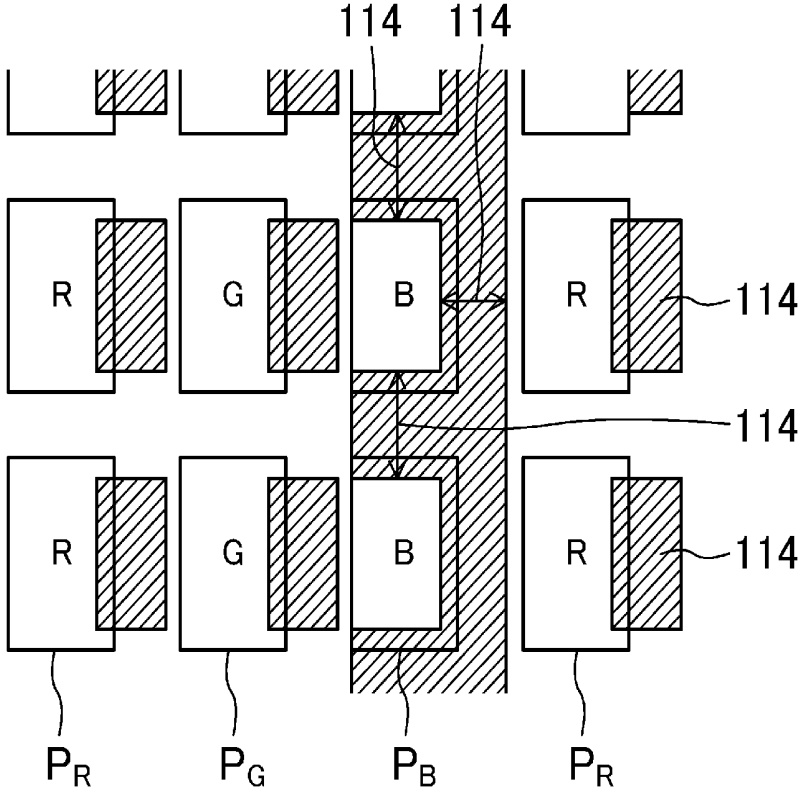

FIG.20

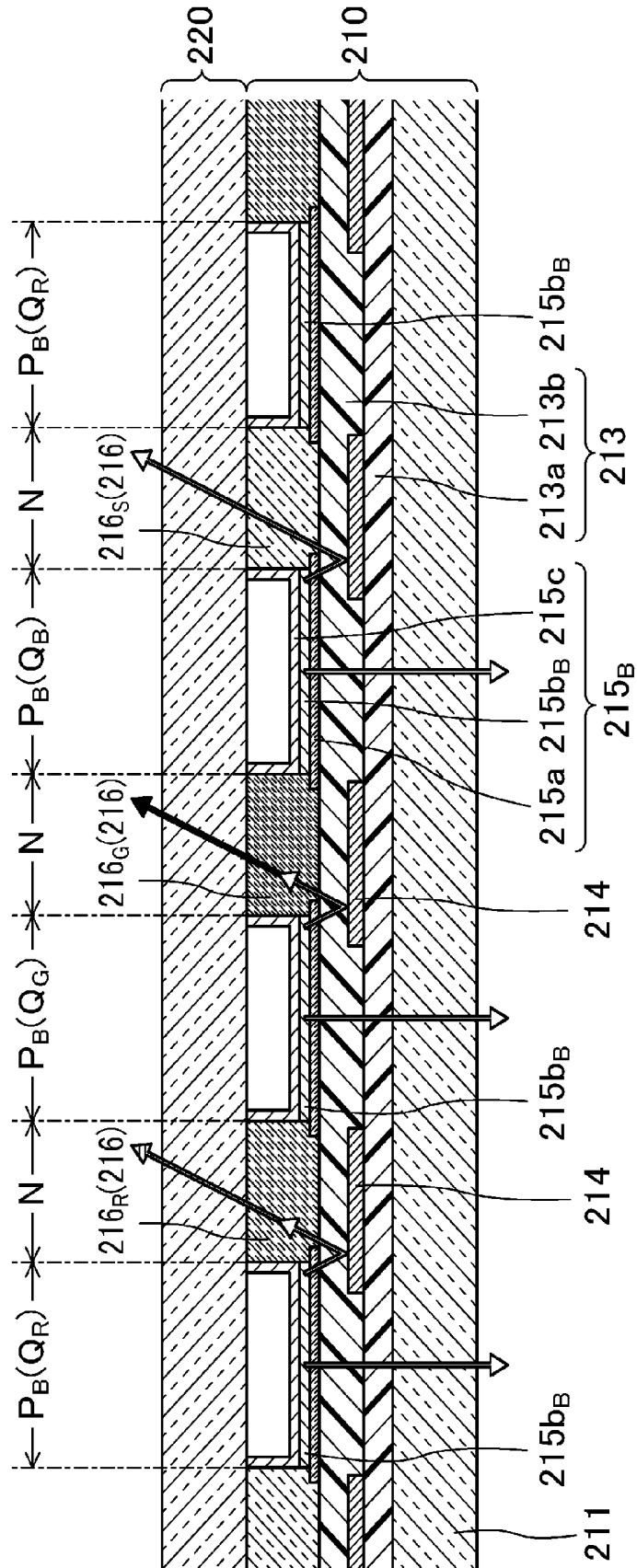

FIG.21A

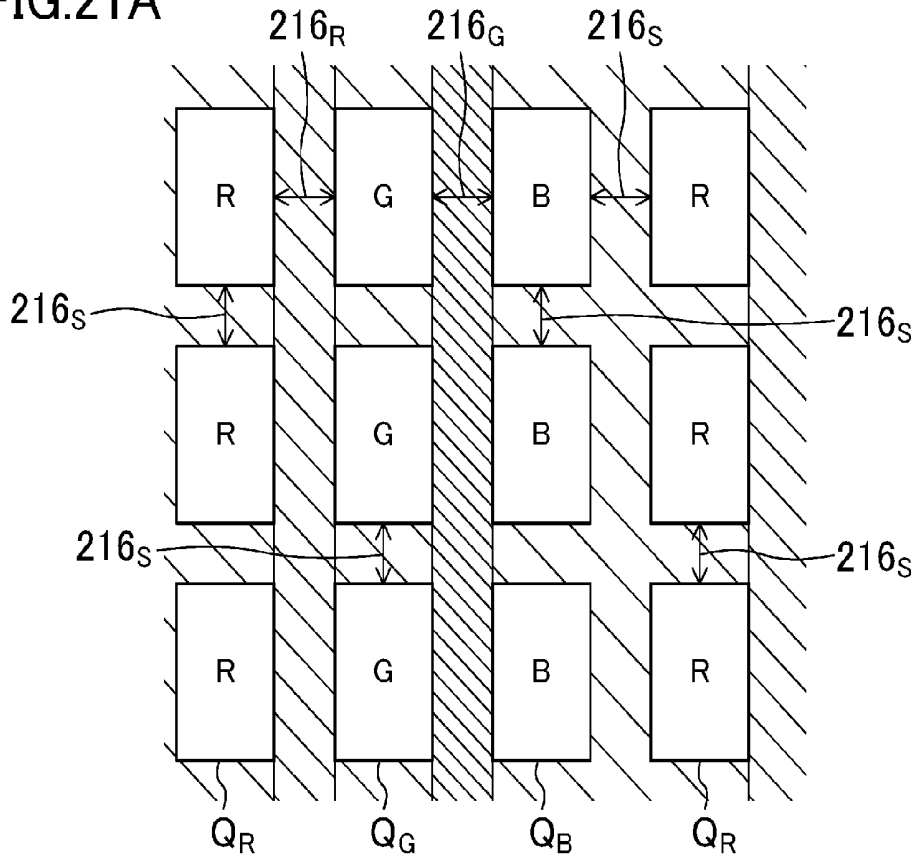

FIG.21B

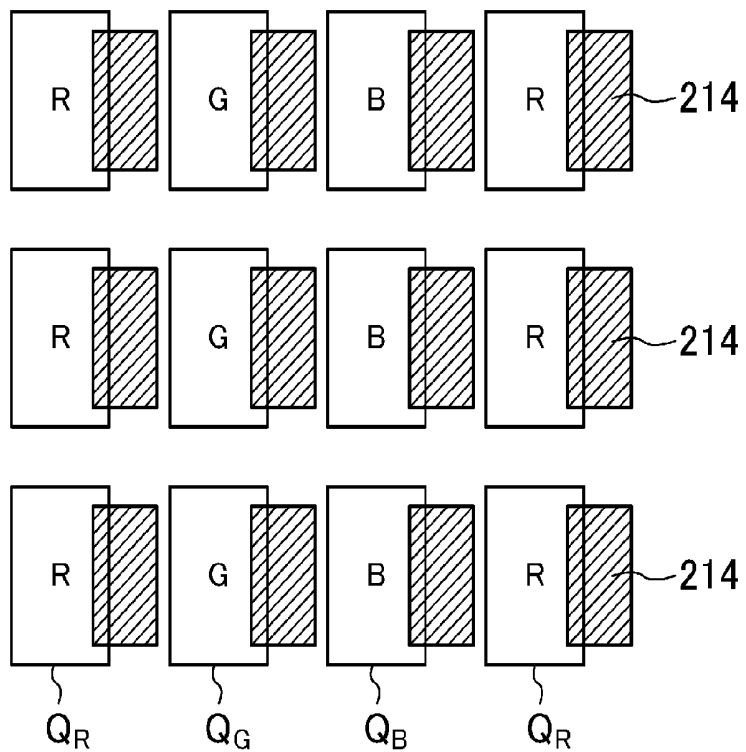

FIG.22

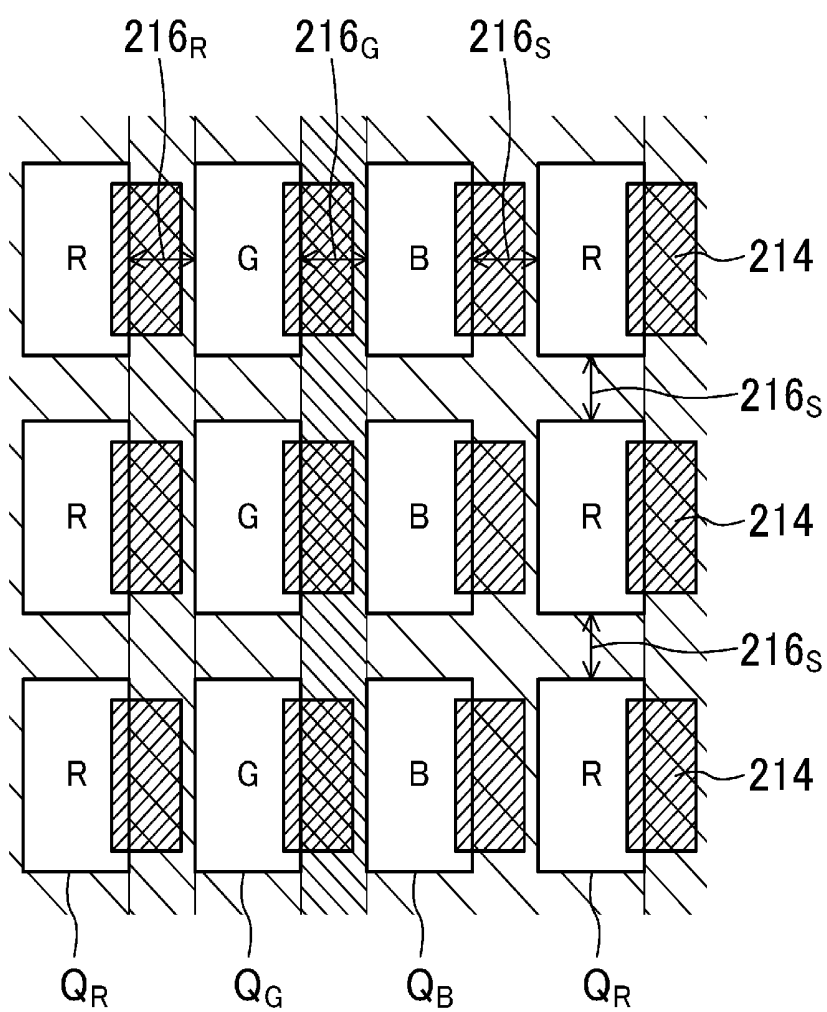

FIG.23A

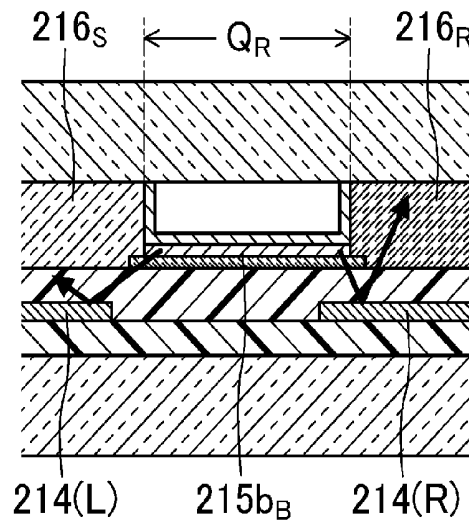

FIG.23B

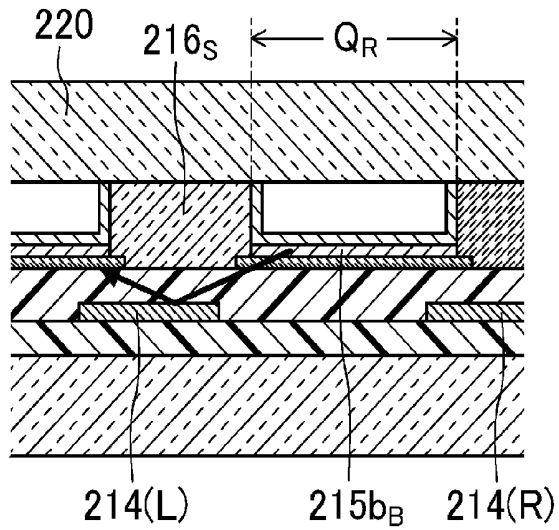

FIG.23C

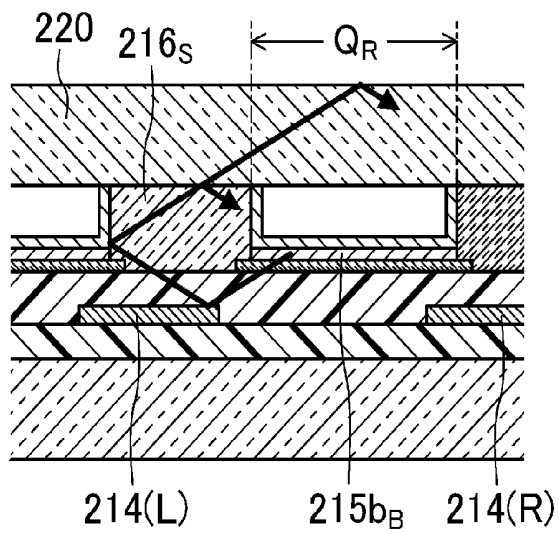

FIG.25

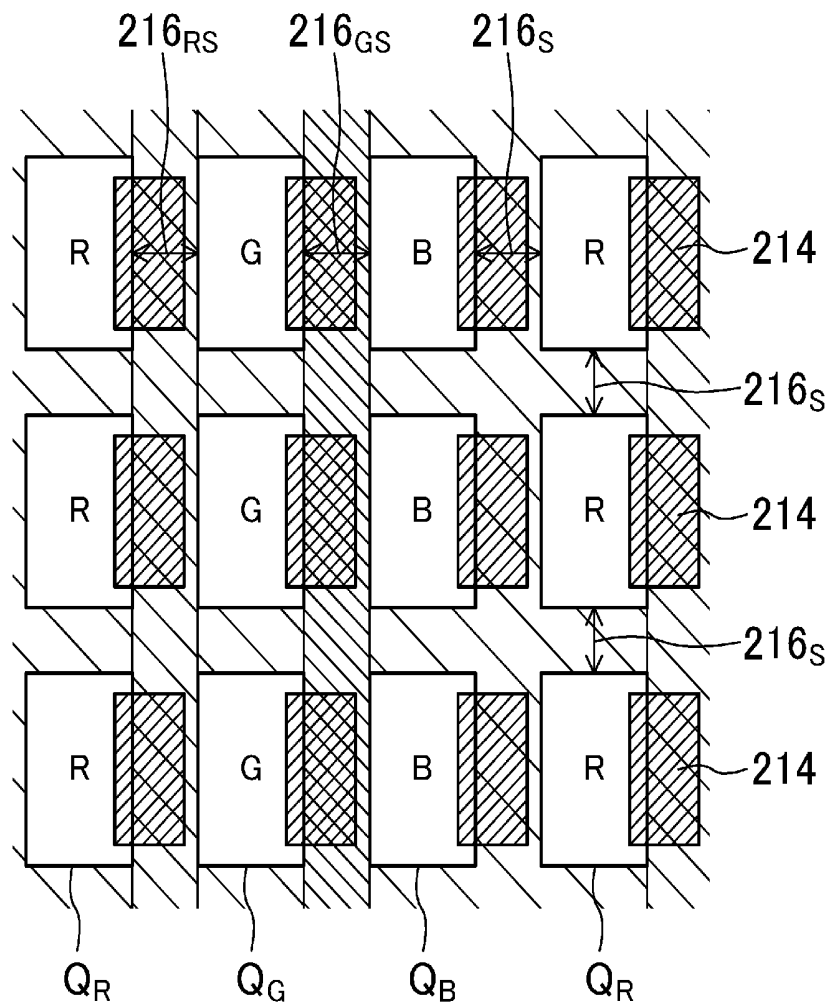

FIG.26A

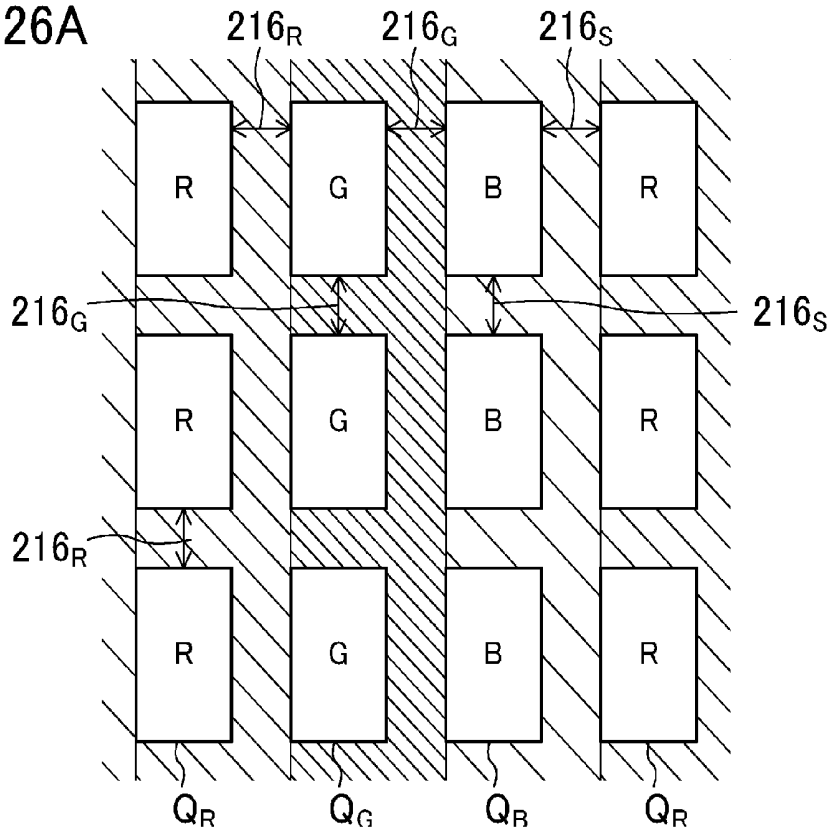

FIG.26B

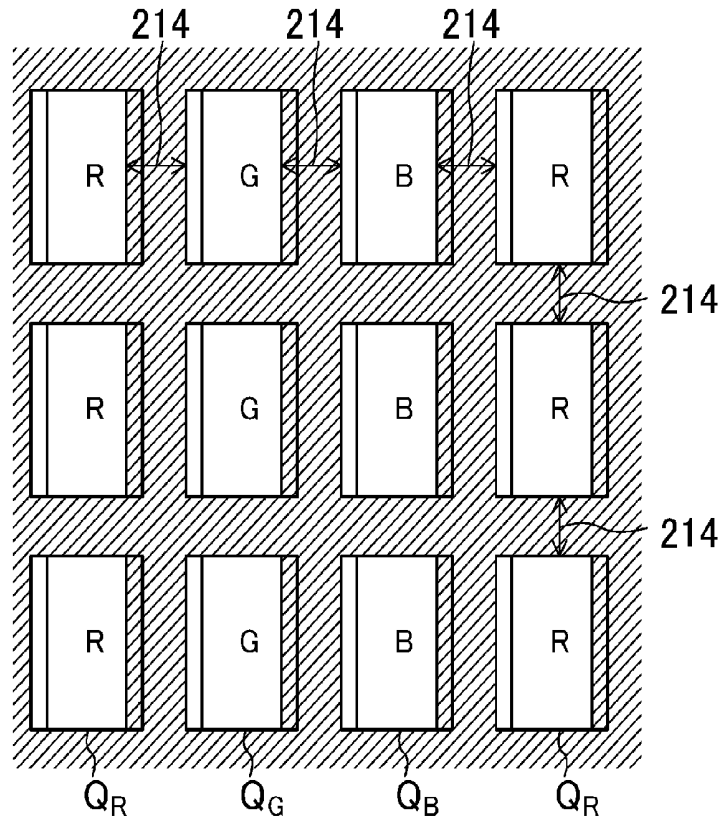

FIG.27

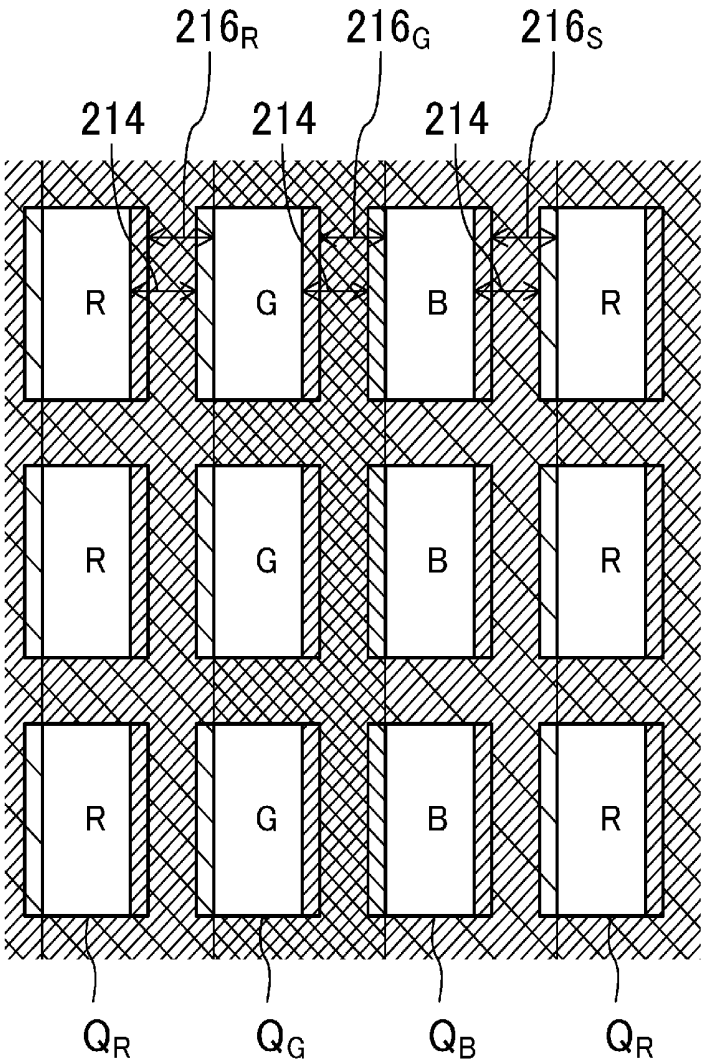

FIG.28A

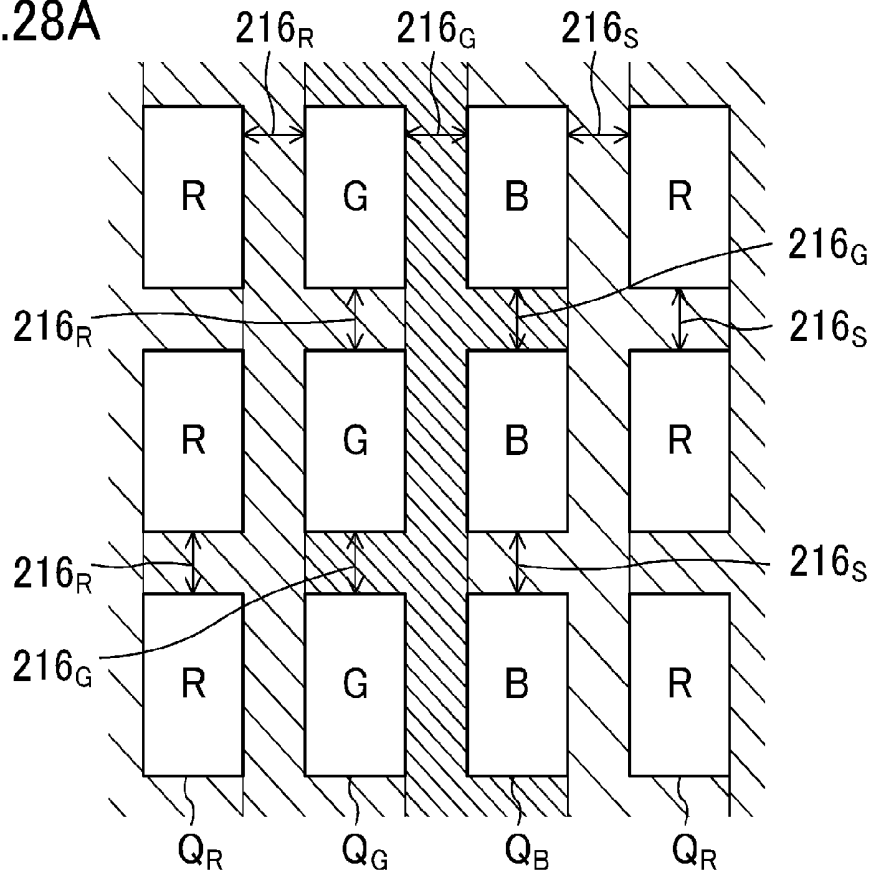

FIG.28B

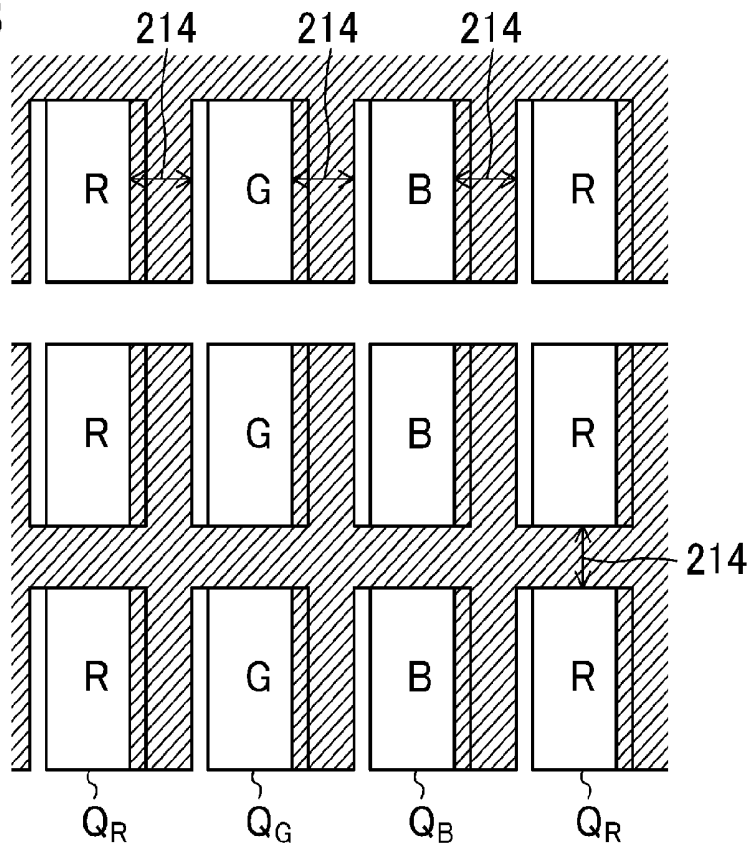

FIG.29

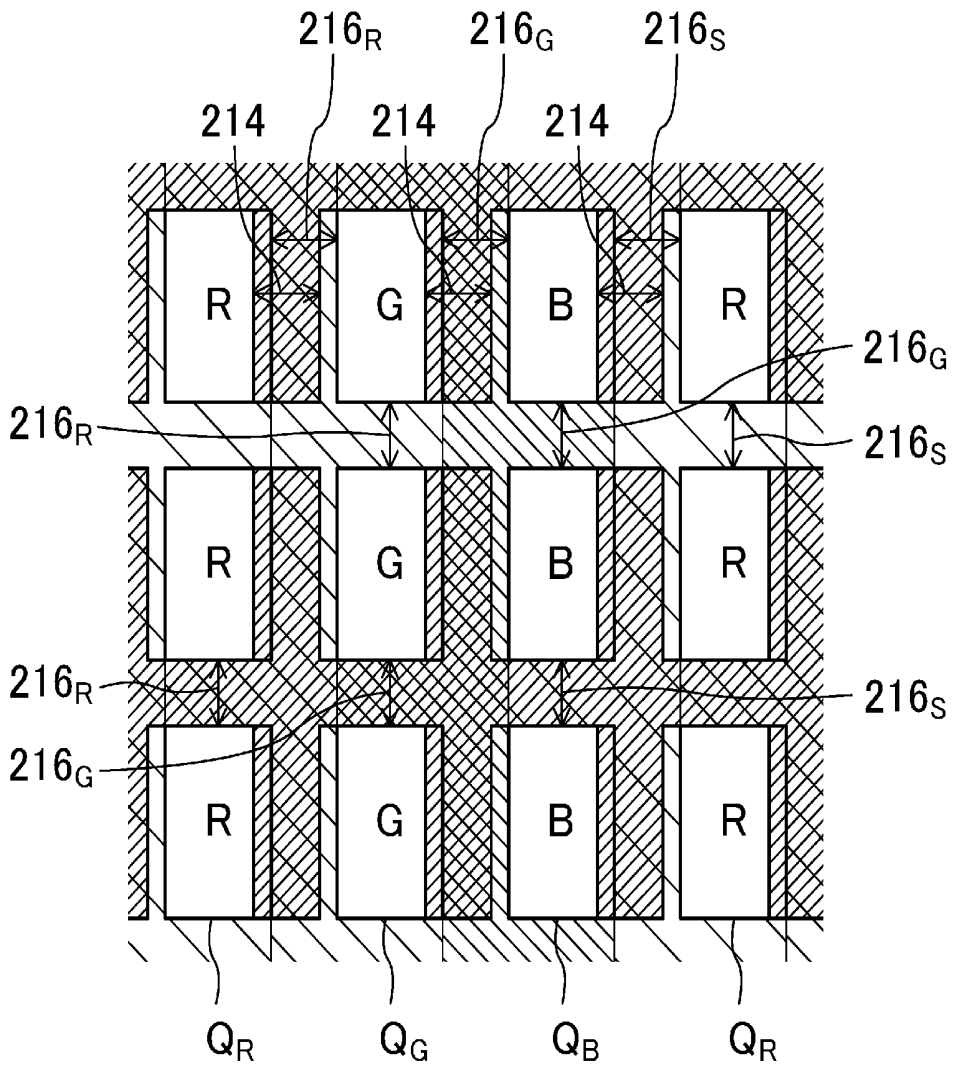

FIG. 30A

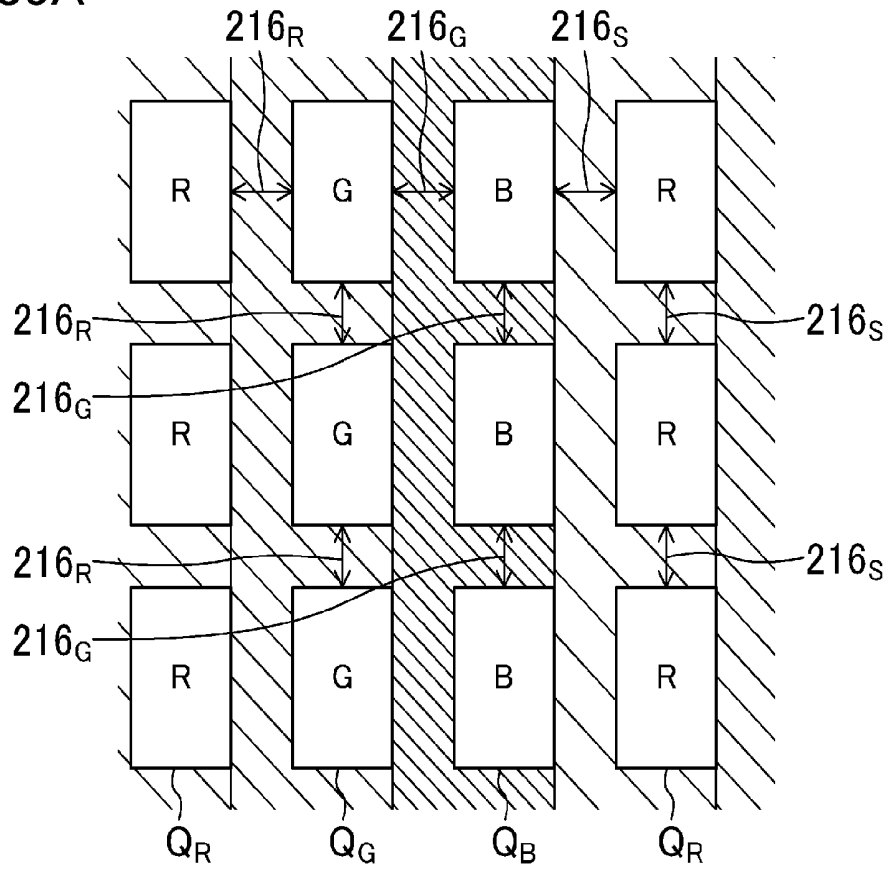

FIG. 30B

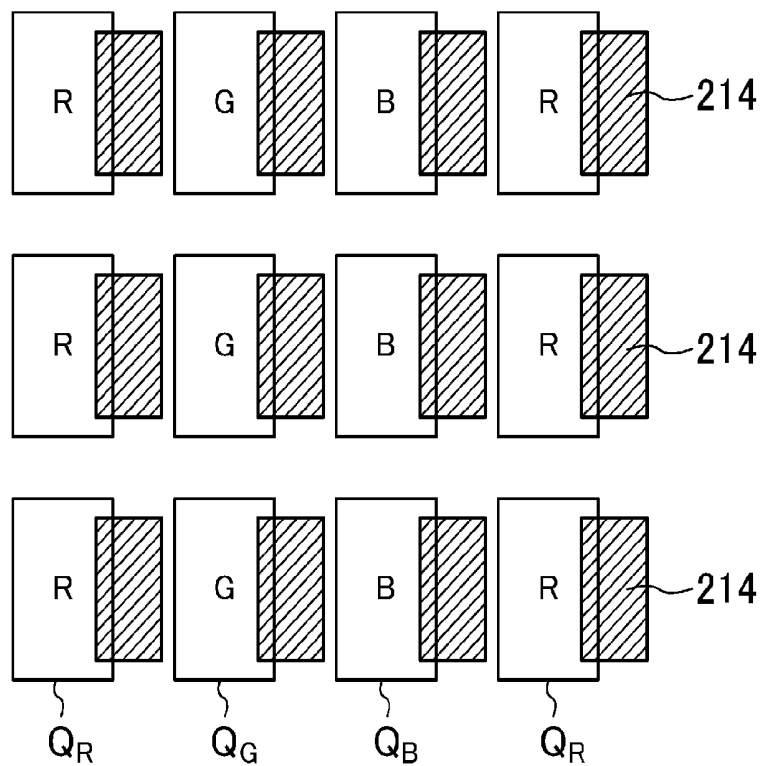

FIG.31

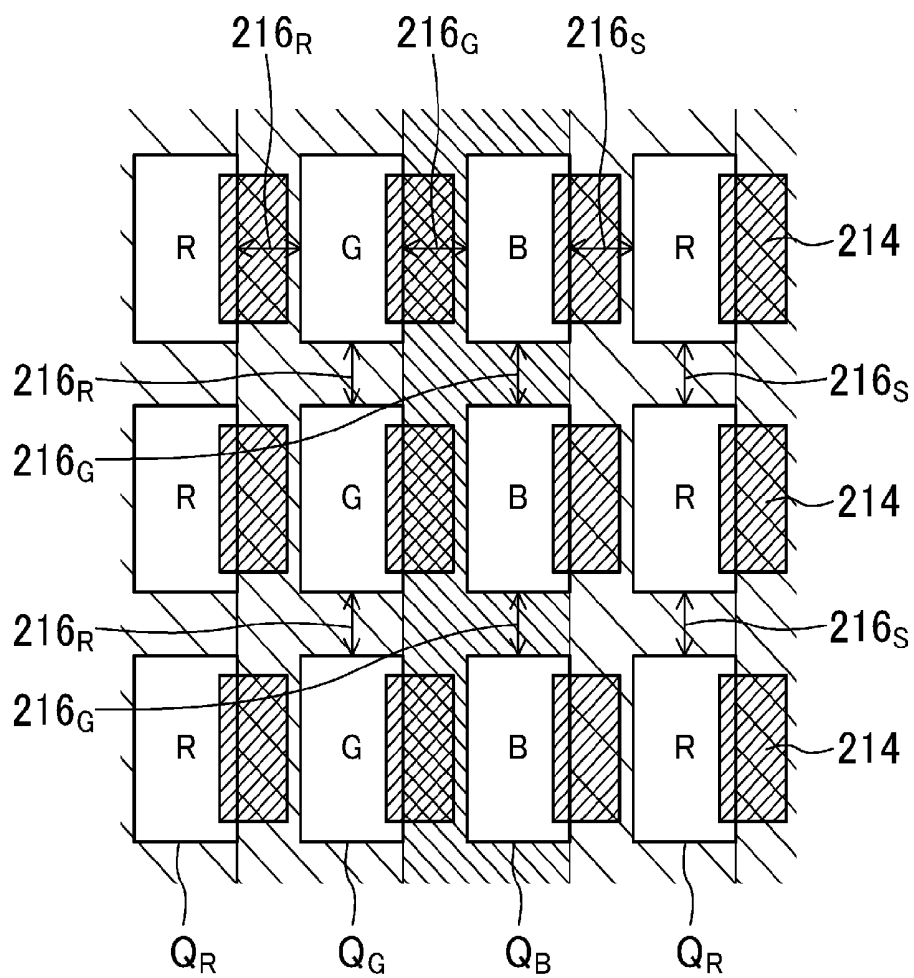

FIG.32

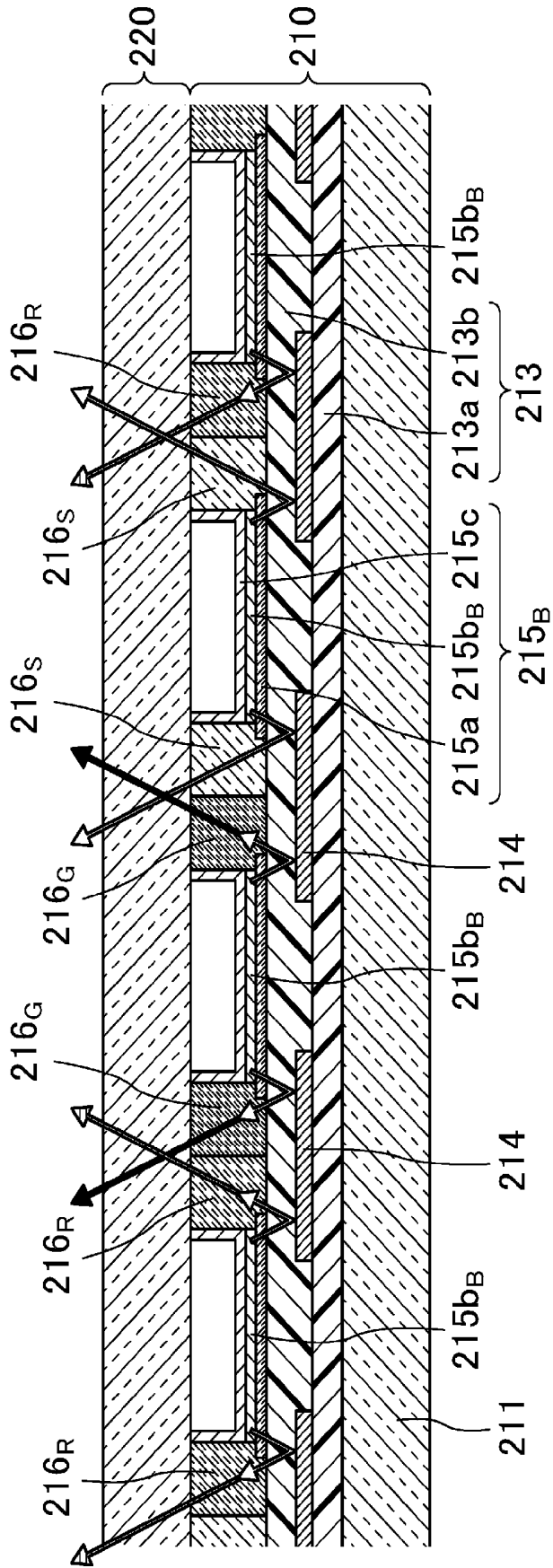

FIG.33A

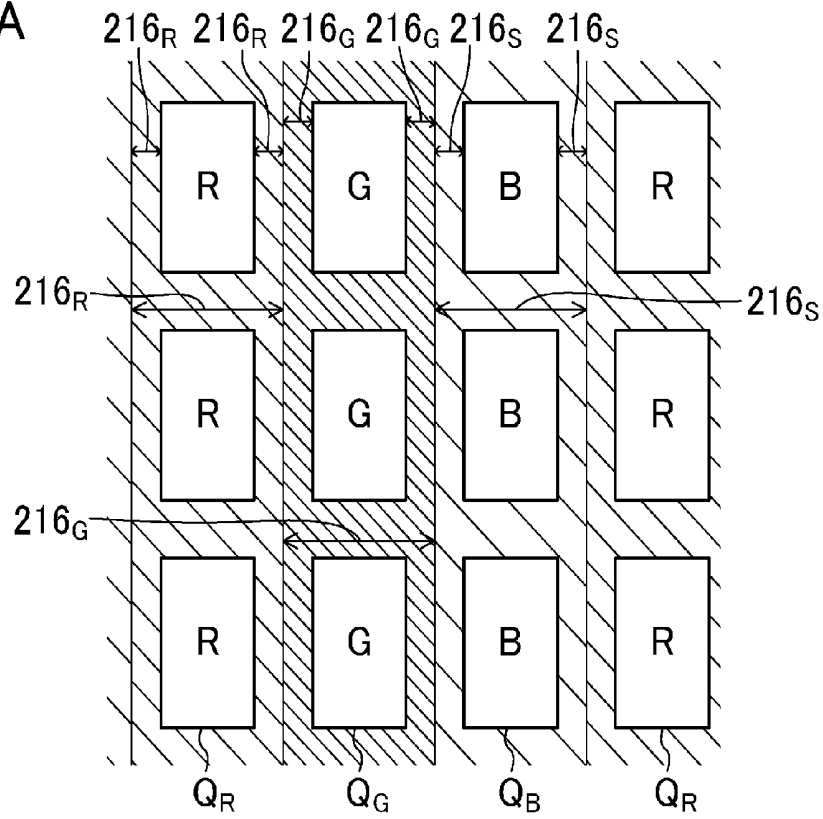

FIG.33B

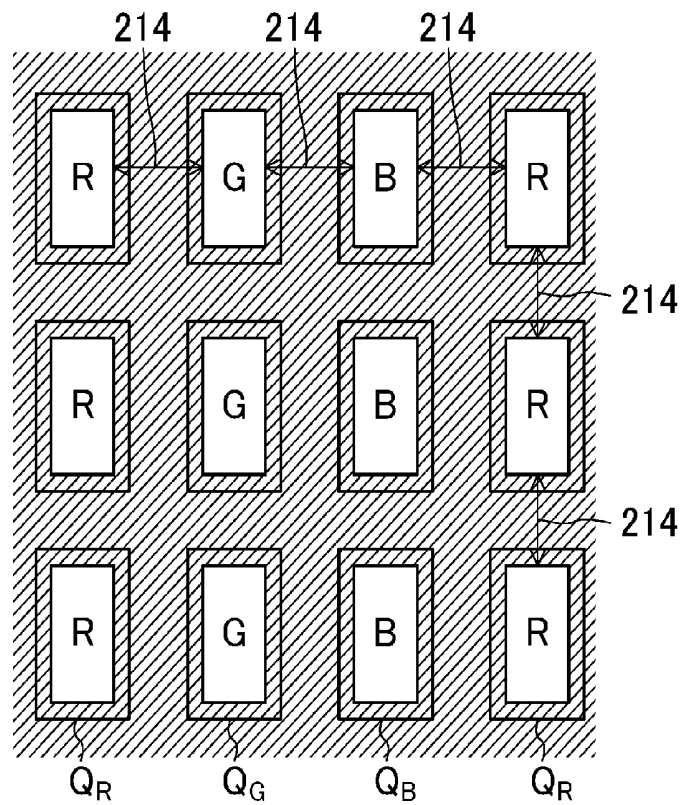

FIG.34

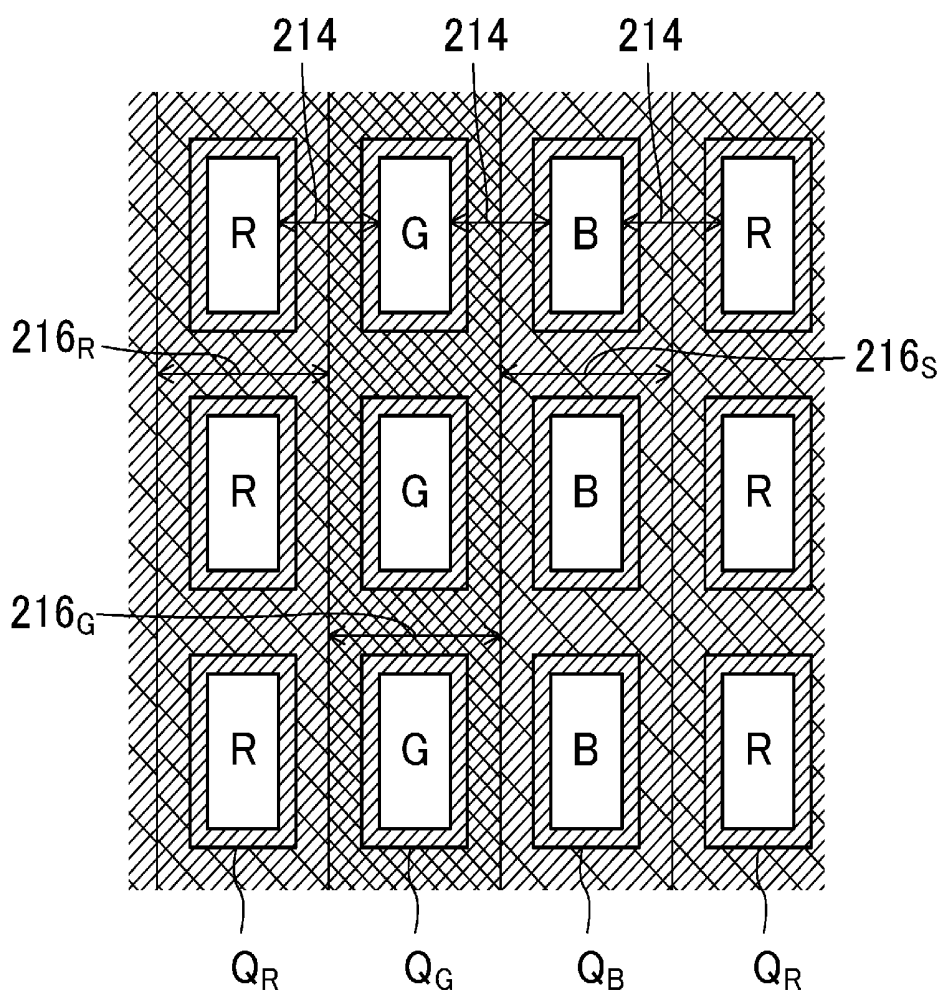

FIG.37A

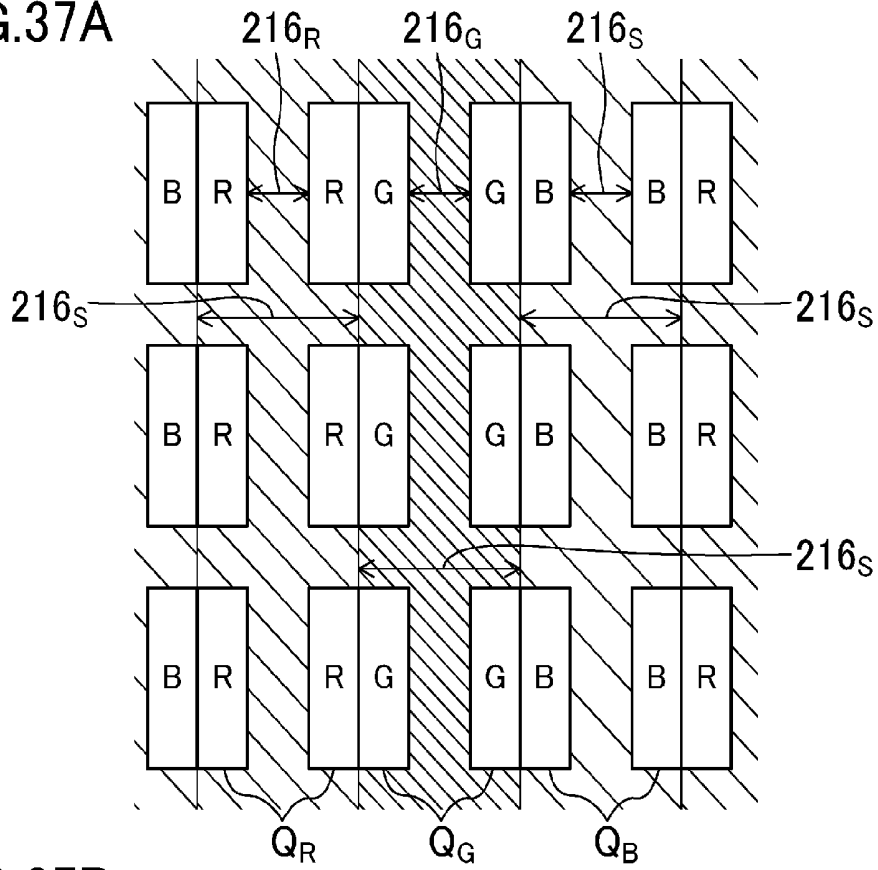

FIG.37B

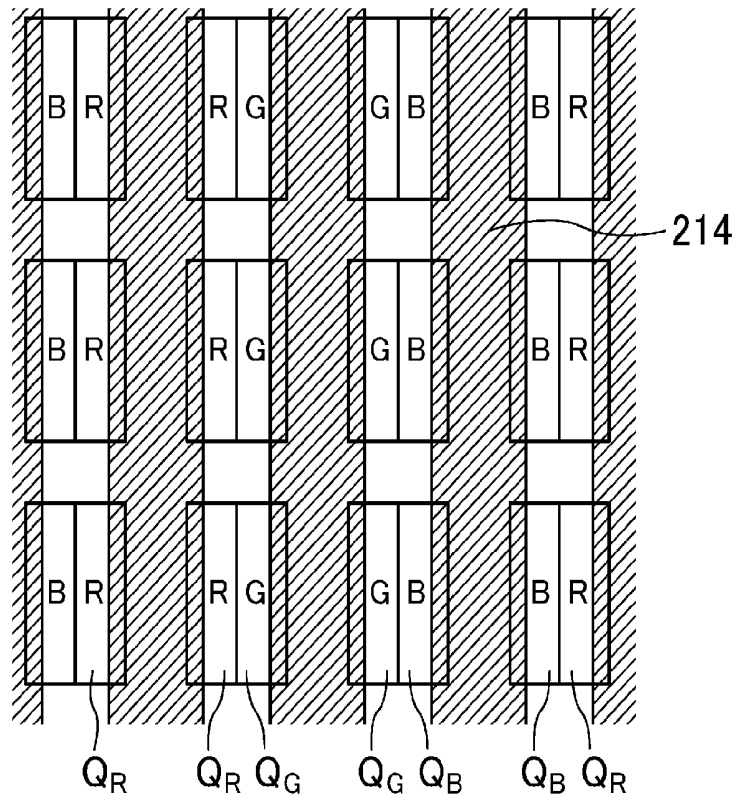
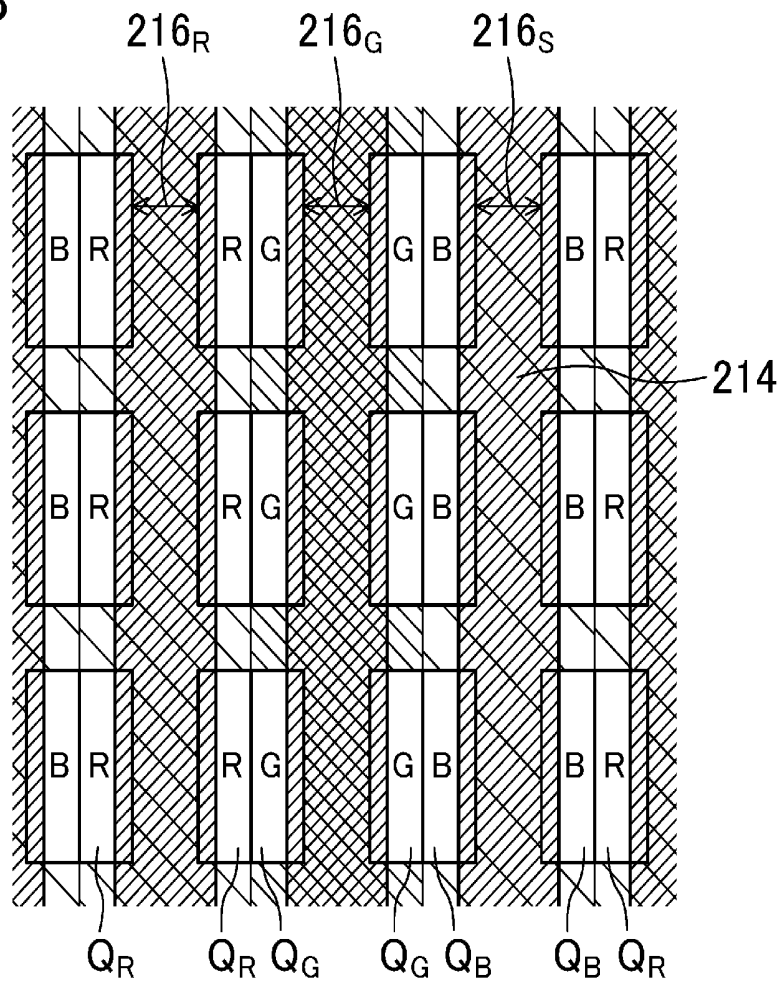

FIG.38



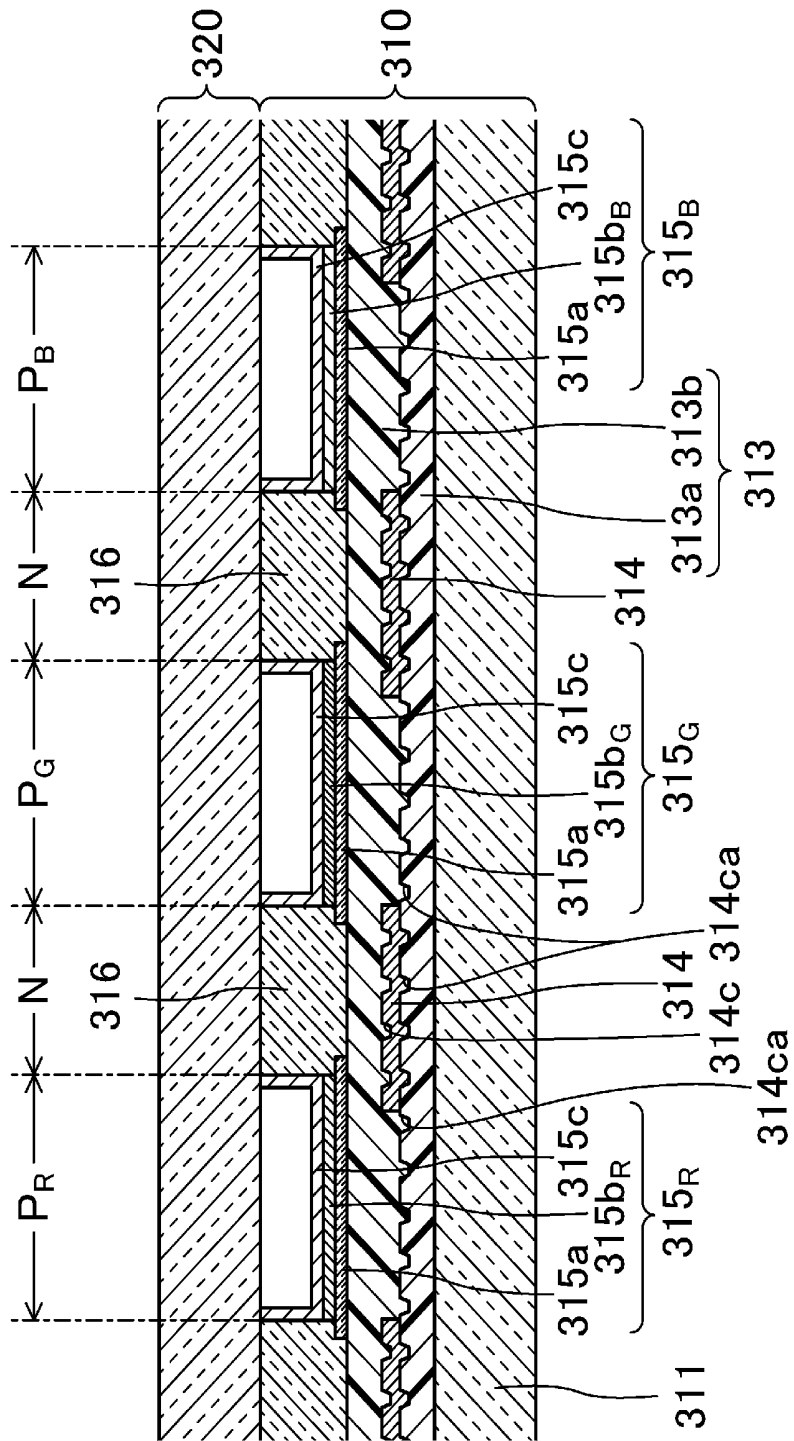
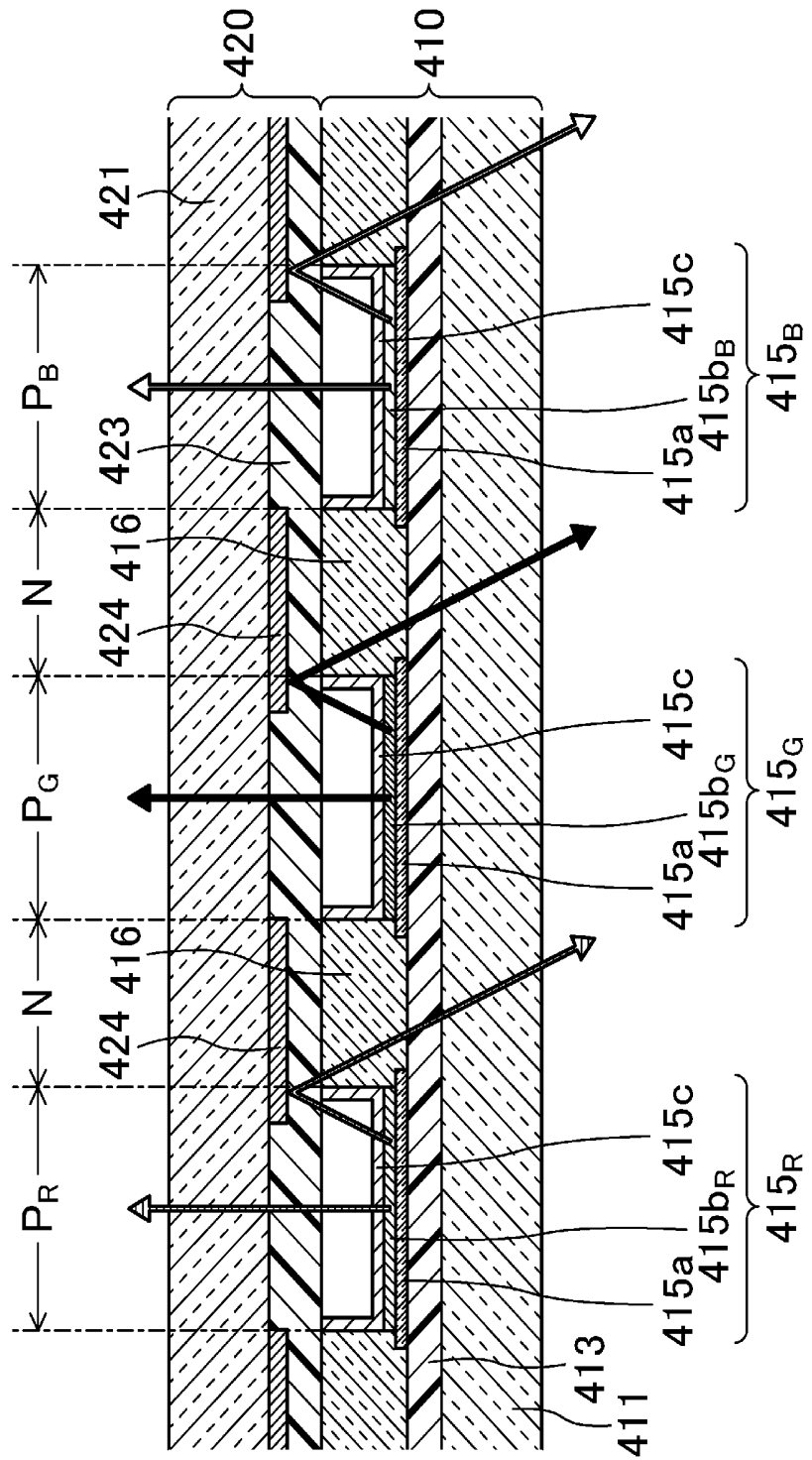

FIG.40

FIG. 41



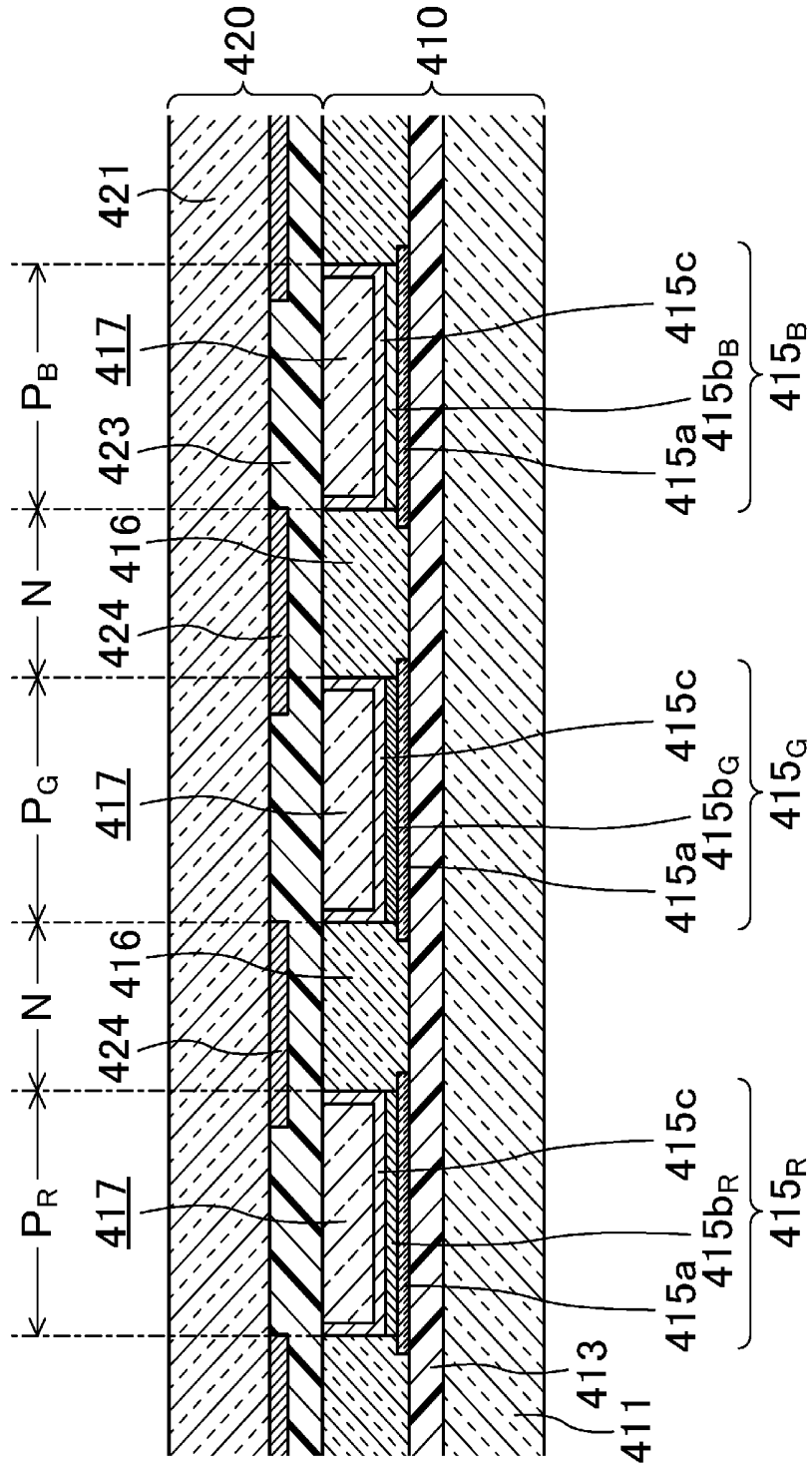

FIG.42

FIG. 43

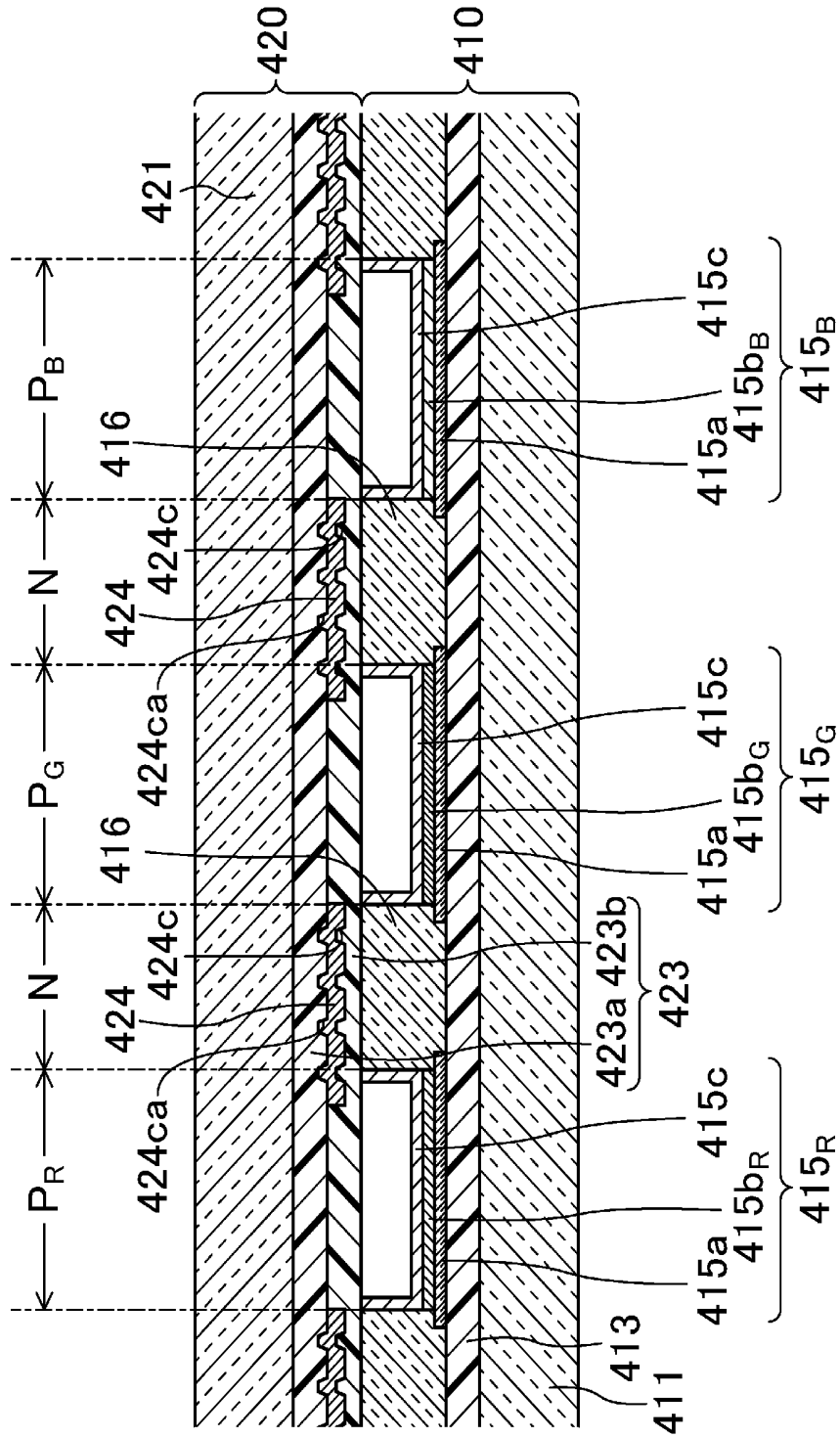

FIG. 44
PRIOR ART

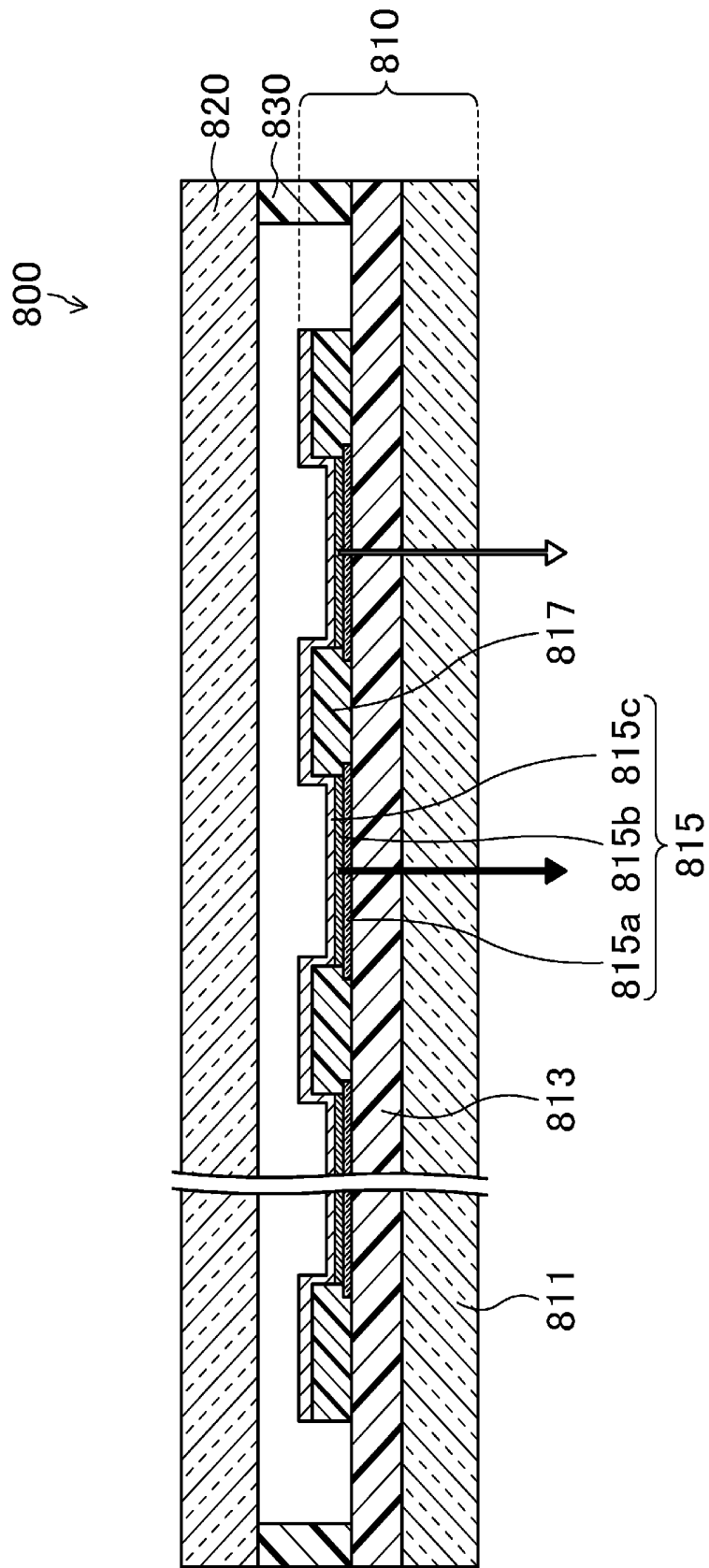
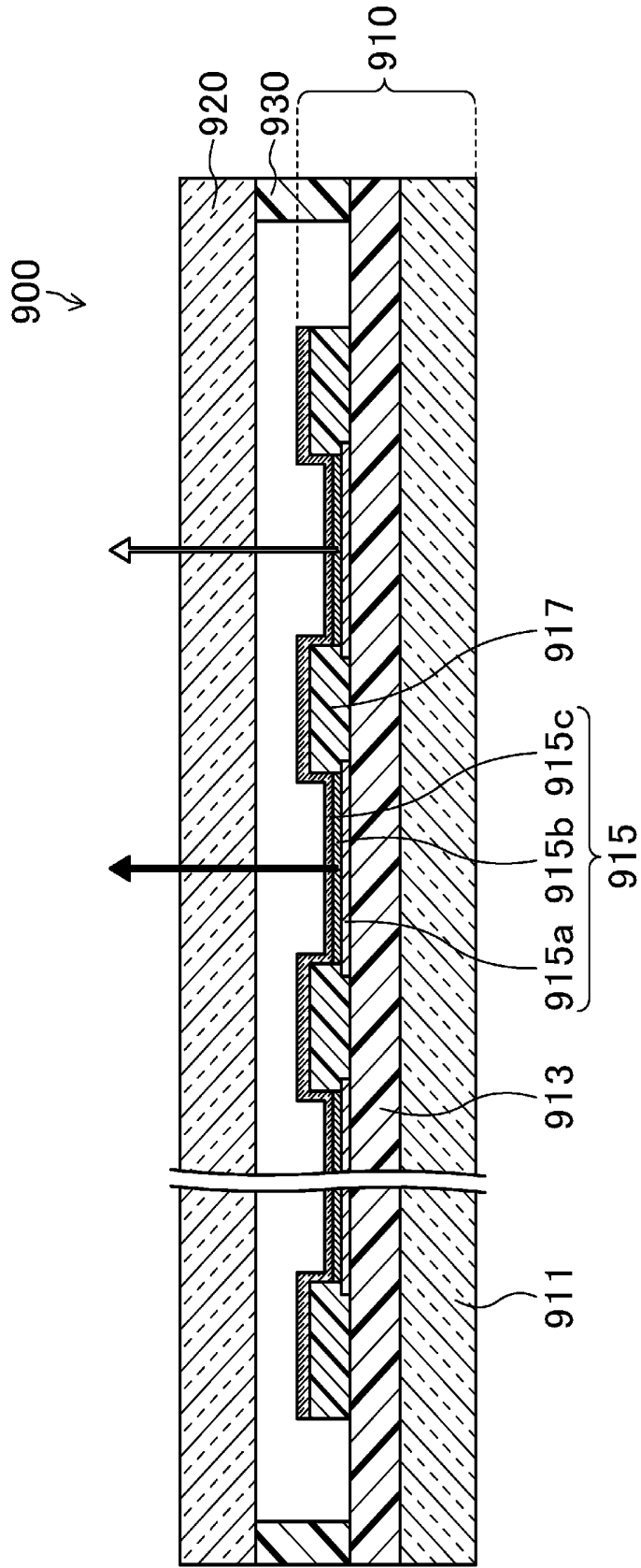

FIG. 45
PRIOR ART



ORGANIC EL DISPLAY DEVICE AND METHOD FOR MANUFACTURING THE SAME

CROSS REFERENCE TO RELATED APPLICATIONS

This is a U.S. National Phase patent application of PCT/JP2012/000603, filed Jan 31, 2012, which claims priority to Japanese patent application no. 2011-023987, filed Feb. 7, 2011, each of which is hereby incorporated by reference in the present disclosure in its entirety.

TECHNICAL FIELD

The present invention relates to double-sided display type organic EL display devices which display an image on both sides of a panel thereof, and methods for manufacturing such display devices.

BACKGROUND ART

Organic electroluminescence (hereinafter also referred to as "organic EL") display devices have in recent years attracted attention as flat panel displays which are excellent in terms of low voltage drive, all solid state, high speed response, self-emission, etc. An organic EL display device includes an organic EL substrate on which organic EL elements are formed, and a sealing substrate which faces the organic EL substrate and seals the organic EL elements. The organic EL substrate has, for example, the following structure: thin film transistors (hereinafter also referred to as "TFTs") are formed on a glass substrate; a planarization film is formed for planarization and insulation of a surface of the glass substrate on which the TFTs are provided; and lower electrodes, an organic layer, and upper electrodes are successively formed, on top of one another, on the planarization film.

Organic EL display devices are roughly divided into the bottom emission type which allows light to be extracted through the side on which the lower electrodes are provided (see FIG. 44), and the top emission type which allows light to be extracted through the side on which the upper electrodes are provided (see FIG. 45). In a bottom emission type organic EL display device, the lower electrode is a transparent electrode of ITO etc., and the upper electrode is a light reflective metal electrode. On the other hand, in a typical top emission type organic EL display device, the lower electrode is a light reflective metal electrode, and the upper electrode is a semi-transparent electrode.

In recent years, on the mobile telephone market, there has been an increasing demand for display devices which can display an image on both front and back sides thereof, i.e., a primary screen (main display) and a secondary screen (sub-display). It has been desired to provide thin and light double-sided display devices having high display quality. In addition to the mobile telephone market, in the fields of display devices (mobile viewers) included in mobile devices, such as multimedia players etc., large-size information bulletin boards (digital signage), etc., the use of double-sided display devices has been expected to increase the range of design or expression or to provide the space saving effect.

Double-sided display devices currently in practical use have two display panels with their backs facing each other. Therefore, there is a limit on a reduction in thickness and weight of the double-sided display device, and at the same time, the use of two display panels is disadvantageous in

terms of cost. Therefore, it is desirable that double-sided display be performed using a single display panel.

As a display device which performs double-sided display using a single display panel, a light emitting type display device is preferable. Attempts have been made to provide an organic EL display device which can perform double-sided display.

PATENT DOCUMENT 1 describes a double-sided organic EL display device in which bottom emission type organic EL elements and top emission type organic EL elements are formed, one on top of the other, on a single pixel circuit.

PATENT DOCUMENT 2 describes an organic EL display device in which each pixel region includes a first region which emits light downward and a second region which emits light upward.

PATENT DOCUMENT 3 describes an organic EL display device in which TFTs, a planarization film, a reflection film, lower electrodes, an organic EL layer, and upper electrodes are successively formed, on top of one another, on a glass substrate, and the reflection film has an opening in a light emission region or the reflection film is provided in an island-like pattern in a light emission region.

CITATION LIST

Patent Documents

PATENT DOCUMENT 1: Japanese Patent Publication No. 2007-073249

PATENT DOCUMENT 2: Japanese Patent Publication No. 2005-340202

PATENT DOCUMENT 3: Japanese Patent Publication No. 2006-140127

SUMMARY OF THE INVENTION

Technical Problem

However, in the double-sided organic EL display device of PATENT DOCUMENT 1, the bottom emission type organic EL elements and the top emission type organic EL elements are formed one on top of the other, and therefore, the number of layers significantly increases, or the step of patterning electrodes or an insulating film on the organic layer is required, leading to a complicated configuration or a decrease in yield. Also, in the double-sided organic EL display device of PATENT DOCUMENT 1, it is necessary to cause a large current to flow in order to provide a sufficient amount of light for front-side display and back-side display, disadvantageously leading to an increase in power consumption.

In the double-sided organic EL display device of PATENT DOCUMENT 2, each pixel region is divided into the upward emission region and the downward emission region in order to perform double-sided display. Therefore, the luminance of display on each side decreases. Therefore, it is necessary to cause a large current to flow in the organic EL element, disadvantageously leading to an increase in power consumption, a decrease in device life, and a degradation in reliability. Also, because organic EL elements for upward emission and organic EL elements for downward emission are formed, the manufacturing process is complicated, leading to a decrease in yield.

In the double-sided organic EL display device of PATENT DOCUMENT 3, similar to the configuration of PATENT DOCUMENT 2, each pixel region is divided into an upward emission region (a region with the reflection film) and a downward emission region (a region without the reflection

film) in order to perform double-sided display. Therefore, the luminance of display on each side decreases. Therefore, it is necessary to cause a large current to flow in the organic EL element, disadvantageously leading to an increase in power consumption, a decrease in device life, and a degradation in reliability. Also, the lower electrode has an opening or is formed above the island-like pattern reflection film, and therefore, an uneven surface (a step-like portion) occurs in the lower electrode, so that it is difficult to form an organic layer having a uniform thickness on the lower electrode. As a result, a short circuit is likely to occur between the lower electrode and the upper electrode.

It is an object of the present invention to provide a double-sided display type organic EL display device which displays an image on both sides of a panel thereof, without an increase in power consumption and with good display quality.

Solution to the Problem

A first invention for achieving the above object is an organic EL display device including an organic EL substrate having a plurality of light emission regions arranged in a matrix, and a sealing substrate, the organic EL substrate and the sealing substrate facing each other, and having a frame-like non-display region provided at a circumferential portion of the substrates, and a display region provided on an inner side of the frame-like non-display region. The organic EL substrate includes an organic EL substrate body, a plurality of switching elements provided on the organic EL substrate body, each corresponding to one of the plurality of light emission regions, an insulating layer covering the organic EL substrate body and the plurality of switching elements and having a flat surface, a plurality of lower electrodes of a light transmissive material provided on the insulating layer, each corresponding to one of the plurality of light emission regions, a separation wall portion of a light transmissive material provided on the insulating layer, corresponding to a region other than the light emission regions, and configured to separate the plurality of light emission regions from each other, a plurality of organic EL layers each covering a corresponding one of the plurality of lower electrodes, and an upper electrode of a light reflective material covering the plurality of organic EL layers. Light generated in the organic EL layers is propagated to the organic EL substrate body to be viewed as an image on the organic EL substrate. The insulating layer includes a first insulating film and a second insulating film provided thereabove. There are a plurality of the upper electrodes each covering a corresponding one of the plurality of organic EL layers. A reflection film is provided between the first and second insulating films, corresponding to the region other than the light emission regions, and is configured to reflect toward the sealing substrate a portion of light generated in each of the organic EL layers which is diffused into the region other than the light emission regions so that the portion of the light is transmitted through the separation wall portion and the sealing substrate to be viewable as an image on the sealing substrate.

According to the first invention, the reflection film is provided between the first and second insulating films, corresponding to the region other than the light emission regions. The reflection film is disposed to reflect toward the sealing substrate a portion of light generated in each of the organic EL layers which is diffused into the region other than the light emission regions so that the portion of the light is transmitted through the separation wall portion and the sealing substrate to be viewable as an image on the sealing substrate. Therefore, light generated in the organic EL layers is propagated to

the organic EL substrate body to be viewed as an image on the organic EL substrate, while light which is propagated toward the organic EL substrate body and is diffused in a diagonal direction into the region other than the light emission regions is reflected by the reflection film to enter the separation wall portion. The upper electrodes are each provided to cover the corresponding one of the organic EL layers, and therefore, the top surface of the separation wall portion is not covered by the upper electrodes. Therefore, the light entering the separation wall portion is transmitted through the separation wall portion without being blocked to enter the sealing substrate, and therefore, is viewed from the outside as an image on the sealing substrate. In other words, by driving a single panel, an image can be displayed on both sides thereof, i.e., the organic EL substrate and the sealing substrate.

According to the first invention, light emitted in a diagonal direction, which is conventionally not effectively used, is used to display an image on the sealing substrate, and therefore, even when double-sided display is performed, the light emission luminance of display on the organic EL substrate is not likely to significantly decrease, and the power consumption is not likely to increase.

In this case, light is transmitted through the separation wall portion corresponding to the region other than the light emission regions to be emitted to the sealing substrate and is therefore viewed as an image on the sealing substrate. Therefore, the large region surrounding the light emission regions is used as a light emission region on the sealing substrate to display an image. Light of the light emission regions is reflected by the reflection film and blended together in the separation wall portion before being displayed on the sealing substrate. Therefore, the boundary between each light emission region on the sealing substrate is less viewable. Therefore, an image can be displayed with high display quality on the sealing substrate as well.

According to the first invention, the second insulating film is provided to cover the reflection film and have a flat surface, i.e., the insulating layer has a flat surface. Therefore, variations in thickness of the organic EL elements including the lower electrode, the organic EL layer, and the upper electrode, which are provided on the insulating layer, are reduced or prevented, resulting in the highly reliable organic EL elements.

According to the first invention, when light generated in the organic EL layers travels toward the organic EL substrate body, the light is propagated through the insulating layer to enter the organic EL substrate body, or is reflected by the reflection film to enter and pass through the separation wall portion **116** directly to the sealing substrate. Therefore, the light does not travel in a gas, and therefore, the loss of the light can be reduced or prevented.

According to the first invention, the upper electrode is formed of a light reflective material and the lower electrode is formed of a light transmissive material. Therefore, an image can be displayed on the sealing substrate without taking into consideration the problem that the color purity or luminance varies depending on the viewing angle due to the influence of interference of light (microcavity effect) which is caused by the light being multiply reflected between the lower and upper electrodes.

A second invention is the first invention in which the reflection film overlaps a circumferential portion of each of the light emission regions.

According to the second invention, the non-transparent upper electrode and the non-transparent reflection film overlap, whereby it is possible to reduce or prevent a reduction in display quality which is caused by external light passing

through the organic EL panel and being thereby viewed on the opposite side of the panel. In addition, the reflection film overlaps a circumferential portion of the light emission region. Therefore, the problem that the light emission area of the light emission region significantly decreases and therefore the luminance of image display on the organic EL substrate decreases, does not arise.

A third invention is the first or second invention in which the separation wall portion functions as a spacer which is in contact with and supports the sealing substrate.

According to the third invention, the separation wall portion functions as a spacer which is in contact with and supports the sealing substrate. Therefore, another spacer is not required in addition to the separation wall portion, and therefore, the aperture ratio of the organic EL display device can be increased. The top surface of the separation wall portion is not covered by the upper electrodes, and the separation wall portion itself is in contact with the sealing substrate. Therefore, the sealing substrate can be supported while a distance between the organic EL substrate and the sealing substrate can be maintained constant.

A fourth invention is any one of the first to third inventions in which the first and second insulating films are each formed of a material having the same refractive index.

According to the fourth invention, when light travels through an interface between the first and second insulating films, the light is not refracted, and therefore, the loss of the light can be reduced or prevented, resulting in excellent light extraction efficiency.

A fifth invention is any one of the first to fourth inventions in which the plurality of light emission regions include red light emission regions configured to emit red light, green light emission regions configured to emit green light, and blue light emission regions configured to emit blue light.

A sixth invention is any one of the first to fourth inventions in which the plurality of light emission regions include blue light emission regions. The separation wall portion includes a red conversion portion configured to convert blue light transmitted through the separation wall portion into red light, a green conversion portion configured to convert blue light transmitted through the separation wall portion into green light, and a transparent resin portion configured not to convert a wavelength of light transmitted through the separation wall portion. Blue light generated in the organic EL layers is propagated to the organic EL substrate body to be viewed as a monochromatic image on the organic EL substrate. A portion of the blue light which is diffused into the region other than the light emission regions is reflected by the reflection film toward the sealing substrate, and is then transmitted through the red and green conversion portions and the transparent resin portion to provide red, green, and blue light, respectively, which are then transmitted through the sealing substrate to be viewed as an RGB full color image on the sealing substrate.

According to the sixth invention, the plurality of light emission regions include blue light emission regions, and therefore, a monochromatic blue image can be displayed on the organic EL substrate. On the other hand, a portion of blue light which is reflected by the reflection film toward the sealing substrate is converted by the red and green conversion portions of the separation wall portion into red and green light, respectively, or is transmitted through the transparent resin portion of the separation wall portion. The resulting red, green, and blue light reach the sealing substrate to be viewed as an RGB full color image on the sealing substrate. In other words, according to the sixth invention, in the organic EL display device which performs double-sided display, a mono-

chromatic image can be displayed on one side, while a full color image can be displayed on the other side.

Note that a color conversion filter can also be used to display a monochromatic image having a color other than blue on the organic EL substrate.

A seventh invention is any one of the first to sixth inventions in which the reflection film has an uneven surface.

According to the seventh invention, the reflection film has an uneven surface. Therefore, when light emitted by the organic EL layers is reflected by the reflection film, the light can be scattered in various directions. Therefore, when light reflected by the reflection film is viewed on the sealing substrate, the light contains many light components which travel in a front direction of the substrate, resulting in excellent display quality on the sealing substrate.

An eighth invention is the seventh invention in which the uneven surface is formed by recessed portions provided on the reflection film.

According to the eighth invention, the uneven surface is formed by recessed portions provided on a surface of the reflection film. Therefore, the uneven surface can be easily provided to the reflection film.

A ninth invention is a method for manufacturing an organic EL display device including an organic EL substrate having a plurality of light emission regions arranged in a matrix, and a sealing substrate, the organic EL substrate and the sealing substrate facing each other, and having a frame-like non-display region provided at a circumferential portion of the substrates, and a display region provided on an inner side of the frame-like non-display region. The method includes an organic EL substrate forming step of producing the organic EL substrate by forming a plurality of switching elements on a substrate body, each corresponding to one of the plurality of light emission regions, forming a first insulating layer covering the substrate body and the plurality of switching elements, forming a reflection film on the first insulating film, corresponding to a region other than the light emission regions, forming a second insulating film covering the first insulating film and the reflection film and having a flat surface, forming a plurality of lower electrodes on the second insulating film, each corresponding to one of the plurality of light emission regions, forming a separation wall portion on the second insulating film, corresponding to the region other than the light emission regions, to separate the plurality of light emission regions from each other, forming a plurality of organic EL layers each covering a corresponding one of the plurality of lower electrodes, and forming a plurality of upper electrodes each covering a corresponding one of the plurality of organic EL layers, and a substrate bonding step of disposing the organic EL substrate produced by the organic EL substrate forming step and the sealing substrate to face each other, and bonding the organic EL substrate and the sealing substrate together at the non-display region. In the organic EL substrate forming step, the reflection film is formed so that a portion of light generated in each of the organic EL layers which is diffused into the region other than the light emission regions is reflected by the reflection film, and is then transmitted through the separation wall portion and the sealing substrate to be viewed as an image on the sealing substrate.

According to the ninth invention, the reflection film is formed on the first insulating film, corresponding to the light emission regions. The reflection film is disposed to reflect toward the sealing substrate a portion of light generated in each of the organic EL layers which is diffused into the region other than the light emission regions so that the portion of the light is transmitted through the separation wall portion and the sealing substrate to be viewable as an image on the sealing

substrate. Therefore, light generated in the organic EL layers is propagated to the organic EL substrate body to be viewed as an image on the organic EL substrate, while light which is propagated toward the organic EL substrate body and is dif-
 fused in a diagonal direction into the region other than the light emission regions is reflected by the reflection film to enter the separation wall portion. The upper electrodes are each provided to cover the corresponding one of the organic EL layers, and therefore, the top surface of the separation wall portion is not covered by the upper electrodes. Therefore, the light entering the separation wall portion is transmitted through the separation wall portion without being blocked to enter the sealing substrate, and therefore, is viewed from the outside as an image on the sealing substrate. In other words, by driving a single panel, an image can be displayed on both sides thereof, i.e., the organic EL substrate and the sealing substrate.

According to the ninth invention, light emitted in a diagonal direction, which is conventionally not effectively used, is used to display an image on the sealing substrate, and therefore, even when double-sided display is performed, the light emission luminance of display on the organic EL substrate is not likely to significantly decrease, and the power consumption is not likely to increase.

In this case, light is transmitted through the separation wall portion corresponding to the region other than the light emission regions to be emitted to the sealing substrate and is therefore viewed as an image on the sealing substrate. Therefore, the large region surrounding the light emission regions is used as a light emission region on the sealing substrate to display an image. Light of the light emission regions is reflected by the reflection film and blended together in the separation wall portion before being displayed on the sealing substrate. Therefore, the boundary between each light emission region on the sealing substrate is less viewable. Therefore, an image can be displayed with high display quality on the sealing substrate as well.

The ninth invention has other advantages similar to those of the first invention.

A tenth invention is the ninth invention in which, in the organic EL substrate forming step, the reflection film is formed to overlap a circumferential portion of each of the light emission regions.

According to the tenth invention, the non-transparent upper electrode and the non-transparent reflection film overlap, whereby it is possible to reduce or prevent a reduction in display quality which is caused by external light passing through the organic EL panel and being thereby viewed on the opposite side of the panel. In addition, the reflection film overlaps a circumferential portion of the light emission region. Therefore, the problem that the light emission area of the light emission region significantly decreases and therefore the luminance of image display on the organic EL substrate decreases, does not arise.

An eleventh invention is the ninth or tenth invention in which, in the substrate bonding step, the sealing substrate and the organic EL substrate are disposed to face each other so that the separation wall portion is in contact with and supports the sealing substrate.

According to the eleventh invention, the sealing substrate and the organic EL substrate are disposed to face each other so that the separation wall portion is in contact with and supports the sealing substrate. Therefore, another spacer is not required in addition to the separation wall portion, and therefore, the aperture ratio of the organic EL display device can be increased. The top surface of the separation wall portion is not covered by the upper electrodes, and the separation wall

portion itself is in contact with the sealing substrate. Therefore, the sealing substrate can be supported while a distance between the organic EL substrate and the sealing substrate can be maintained constant.

A twelfth invention is any one of the ninth to eleventh inventions in which, in the organic EL substrate forming step, after the formation of the first insulating film, a recessed portion is formed on at least a surface of a region in which the reflection film is to be formed, and after the formation of the recessed portion, the reflection film is formed on top of the recessed portion formed on the surface of the first insulating film, whereby the reflection film having a recessed portion on a surface thereof is formed.

According to the twelfth invention, after a recessed portion is formed on the surface of the first insulating film, the reflection film is formed on top of the first insulating film. Therefore, a recessed portion is formed on the surface of the reflection film as well, corresponding to the recessed portion of the surface of the first insulating film. Because of the recessed portion formed on the surface of the reflection film, when light emitted by the organic EL layers is reflected by the reflection film, the light can be scattered in various directions. As a result, when light reflected by the reflection film is viewed on the sealing substrate, the light contains many light components which travel in a front direction of the substrate, resulting in excellent display quality on the sealing substrate.

A thirteenth invention is the twelfth invention in which a plurality of recessed portions are formed on the entire surface of the first insulating film.

According to the thirteenth invention, recessed portions are formed on the entire surface of the first insulating film in addition to the region where the reflection film is to be formed. Therefore, recessed portions can be easily formed on the first insulating film irrespective of the region where the reflection film is to be formed. The second insulating film is formed on a portion of the first insulating film in which a recessed portion is formed but the reflection film is not to be formed, whereby the recessed portion is filled with the second insulating film. In particular, when the first and second insulating films are each formed of a material having the same refractive index, then even if light travels through an interface between the recessed portion of the first insulating film and the second insulating film, the loss of the light does not occur, and therefore, the efficiency of light extraction does not decrease.

A fourteenth invention is an organic EL display device including an organic EL substrate having a plurality of light emission regions arranged in a matrix, and a sealing substrate, the organic EL substrate and the sealing substrate facing each other, and having a frame-like non-display region provided at a circumferential portion of the substrates, and a display region provided on an inner side of the frame-like non-display region. The organic EL substrate includes an organic EL substrate body, a plurality of switching elements provided on the organic EL substrate body, each corresponding to one of the plurality of light emission regions, an insulating layer covering the organic EL substrate body and the plurality of switching elements and having a flat surface, a plurality of lower electrodes of a light reflective material provided on the insulating layer, each corresponding to one of the plurality of light emission regions, a separation wall portion of a light transmissive material provided on the insulating layer, corresponding to a region other than the light emission regions, and configured to separate the plurality of light emission regions from each other, a plurality of organic EL layers each covering a corresponding one of the plurality of lower electrodes, and an upper electrode of a light transmissive material or a

light semi-transmissive material covering the plurality of organic EL layers. Light generated in the organic EL layers is propagated to the sealing substrate to be viewed as an image on the sealing substrate. There are a plurality of the upper electrodes each covering a corresponding one of the plurality of organic EL layers. A reflection film is provided on a surface closer to the organic EL substrate of the sealing substrate, corresponding to the region other than the light emission regions, and is configured to reflect toward the organic EL substrate a portion of light generated in each of the organic EL layers which is diffused into the region other than the light emission regions so that the portion of the light is transmitted through the separation wall portion and the organic EL substrate body substrate to be viewable as an image on the organic EL substrate.

According to the fourteenth invention, the reflection film is provided on the surface closer to the organic EL substrate of the sealing substrate, corresponding to the region other than the light emission regions, and is disposed to reflect toward the organic EL substrate body a portion of light generated in each of the organic EL layers which is diffused into the region other than the light emission regions so that the portion of the light is transmitted through the separation wall portion and the organic EL substrate body to be viewable as an image on the organic EL substrate. Therefore, light generated in the organic EL layers is propagated to the sealing substrate to be viewed as an image on the sealing substrate, while light which is propagated toward the sealing substrate and is diffused in a diagonal direction into the region other than the light emission regions is reflected by the reflection film to enter the separation wall portion. In this case, because the upper electrodes are each provided to cover the corresponding one of the organic EL layers, i.e., the top surface of the separation wall portion is not covered by the upper electrodes, the light reflected by the reflection film can enter the separation wall portion. The light entering the separation wall portion is transmitted through the separation wall portion without being blocked to enter the organic EL substrate body, and therefore, is viewed from the outside as an image on the organic EL substrate. Therefore, by driving a single panel, an image can be displayed on both sides thereof, i.e., the organic EL substrate and the sealing substrate.

According to the fourteenth invention, light emitted in a diagonal direction, which is conventionally not effectively used, is used to display an image on the organic EL substrate, and therefore, even when double-sided display is performed, the light emission luminance of display on the sealing substrate is not likely to significantly decrease, and the power consumption is not likely to increase.

In this case, light is transmitted through the separation wall portion corresponding to the region other than the light emission regions to be emitted to the organic EL substrate body and is therefore viewed as an image on the organic EL substrate. Therefore, the large region surrounding the light emission regions is used as a light emission region on the organic EL substrate to display an image. Light of the light emission regions is reflected by the reflection film and blended together in the separation wall portion before being displayed on the organic EL substrate. Therefore, the boundary between each light emission region on the organic EL substrate is less viewable. Therefore, an image can be displayed with high display quality on the organic EL substrate as well.

A fifteenth invention is the fourteenth invention in which the upper electrode is formed of a light transmissive material.

According to the fifteenth invention, the upper electrode is formed of a light transmissive material. Therefore, an image can be displayed on the sealing substrate without taking into

consideration the problem that the color purity or luminance varies depending on the viewing angle due to the influence of interference of light (microcavity effect) which is caused by the light being multiply reflected between the lower and upper electrodes.

A sixteenth invention is the fourteenth or fifteenth invention in which the reflection film overlaps a circumferential portion of each of the light emission regions.

According to the sixteenth invention, the non-transparent lower electrode and the non-transparent reflection film overlap, whereby it is possible to reduce or prevent a reduction in display quality which is caused by external light passing through the organic EL panel and being thereby viewed on the opposite side of the panel. In addition, the reflection film overlaps a circumferential portion of the light emission region. Therefore, the problem that the light emission area of the light emission region significantly decreases and therefore the luminance of image display on the organic EL substrate decreases, does not arise.

A seventeenth invention is any one of the fourteenth to sixteenth inventions in which a space between the organic EL substrate and the sealing substrate is filled with a transparent resin.

According to the seventeenth invention, when light emitted by the organic EL layer travels toward the sealing substrate, the light is transmitted through the transparent resin, but not through a gas, to enter the sealing substrate, or is reflected by the reflection film to enter the separation wall portion. Therefore, compared to the case where light travels in a gas when the space between the two substrates is not filled with a transparent resin, the loss of the light can be reduced or prevented.

Advantages of the Invention

According to the present invention, an image displayed on the sealing substrate or the organic EL substrate is formed using light which is emitted in a diagonal direction from the organic EL elements. In an organic EL display device having a conventional configuration, light emitted in a diagonal direction from the organic EL elements is confined between the substrates, and absorbed and thermally deactivated by component materials, or emitted from the end facets of the substrates, and therefore, is not effectively used. However, in the present invention, the light emitted in a diagonal direction is used to display an image on the sealing substrate, and therefore, even when double-sided display is performed, the light emission luminance of display on the organic EL substrate or the sealing substrate is not likely to significantly decrease, and the power consumption is not likely to increase. Therefore, the organic EL display device can display an image on both sides of the panel with high display quality and without an increase in power consumption.

BRIEF DESCRIPTION OF THE DRAWINGS

[FIG. 1] FIG. 1 is a schematic plan view of an organic EL display device according to a first embodiment.

[FIG. 2] FIG. 2 is a cross-sectional view taken along line II-II of FIG. 1.

[FIG. 3] FIG. 3 is an enlarged plan view of a display region of the organic EL display device of the first embodiment.

[FIG. 4] FIG. 4 is a cross-sectional view taken along line IV-IV of FIG. 3.

[FIG. 5] FIG. 5 is an enlarged plan view of one light emission region of an organic EL substrate of the first embodiment.

[FIG. 6] FIG. 6 is a cross-sectional view taken along line VI-VI of FIG. 5.

[FIG. 7] FIG. 7 is a schematic plan view of a layout of color light emission regions and reflection films of the organic EL substrate of the first embodiment.

[FIG. 8] FIG. 8 is a diagram for describing a shape of a separation wall portion of the organic EL display device of the first embodiment.

[FIG. 9] FIG. 9 is a diagram for describing another shape of the separation wall portion of the organic EL display device of the first embodiment.

[FIG. 10] FIGS. 10(a)-10(c) are diagrams for describing a method for manufacturing the organic EL display device of the first embodiment.

[FIG. 11] FIGS. 11(a) and 11(b) are diagrams for describing the method for manufacturing the organic EL display device of the first embodiment.

[FIG. 12] FIG. 12 is a schematic plan view of a layout of color light emission regions and reflection films of an organic EL display device according to Variation 1.

[FIG. 13] FIG. 13 is a schematic plan view of a layout of color light emission regions and reflection films of an organic EL display device according to Variation 2.

[FIG. 14] FIG. 14 is a cross-sectional view of the organic EL display device of Variation 2.

[FIG. 15] FIG. 15 is a schematic plan view of a layout of color light emission regions and reflection films of an organic EL display device according to Variation 3.

[FIG. 16] FIG. 16 is a schematic plan view of a layout of color light emission regions and reflection films of an organic EL display device according to Variation 4.

[FIG. 17] FIG. 17 is a schematic plan view of a layout of color light emission regions and a reflection film of an organic EL display device according to Variation 5.

[FIG. 18] FIG. 18 is a schematic plan view of a layout of color light emission regions and reflection films of an organic EL display device according to Variation 6.

[FIG. 19] FIG. 19 is a schematic plan view of a layout of color light emission regions and reflection films of an organic EL display device according to Variation 7.

[FIG. 20] FIG. 20 is a cross-sectional view of an organic EL display device according to a second embodiment.

[FIG. 21] FIG. 21(a) is a schematic plan view of a layout of color light emission control regions and a separation wall portion (color conversion portions and transparent resin portions) of the organic EL display device of the second embodiment. FIG. 21(b) is a schematic plan view of a layout of light emission regions and reflection films of the organic EL display device of the second embodiment.

[FIG. 22] FIG. 22 is a schematic plan view of a layout of the color light emission control regions, the separation wall portion (color conversion portions and transparent resin portions), and the reflection films of the organic EL display device of the second embodiment.

[FIG. 23] FIGS. 23(a)-23(c) are diagrams for describing paths of light reflected by reflection films.

[FIG. 24] FIG. 24 is a cross-sectional view of an organic EL display device according to Variation 8.

[FIG. 25] FIG. 25 is a schematic plan view of a layout of color light emission control regions, a separation wall portion (color conversion portions and transparent resin portions), and reflection films of the organic EL display device of Variation 8.

[FIG. 26] FIG. 26(a) is a schematic plan view of a layout of color light emission control regions and a separation wall portion (color conversion portions and transparent resin portions) of an organic EL display device according to Variation

9. FIG. 26(b) is a schematic plan view of a layout of light emission regions and a reflection film of the organic EL display device of Variation 9.

[FIG. 27] FIG. 27 is a schematic plan view of a layout of the color light emission control regions, the separation wall portion (color conversion portions and transparent resin portions), and the reflection film of the organic EL display device of Variation 9.

[FIG. 28] FIG. 28(a) is a schematic plan view of a layout of color light emission control regions and a separation wall portion (color conversion portions and transparent resin portions) of an organic EL display device according to Variation 10. FIG. 28(b) is a schematic plan view of a layout of light emission regions and a reflection film of the organic EL display device of Variation 10.

[FIG. 29] FIG. 29 is a schematic plan view of a layout of the color light emission control regions, the separation wall portion (color conversion portions and transparent resin portions), and the reflection film of the organic EL display device of Variation 10.

[FIG. 30] FIG. 30(a) is a schematic plan view of a layout of color light emission control regions and a separation wall portion (color conversion portions and transparent resin portions) of an organic EL display device according to Variation 11. FIG. 30(b) is a schematic plan view of a layout of light emission regions and reflection films of the organic EL display device of Variation 11.

[FIG. 31] FIG. 31 is a schematic plan view of a layout of the color light emission control regions, the separation wall portion (color conversion portions and transparent resin portions), and the reflection films of the organic EL display device of Variation 11.

[FIG. 32] FIG. 32 is a cross-sectional view of an organic EL display device according to Variation 12.

[FIG. 33] FIG. 33(a) is a schematic plan view of a layout of color light emission control regions and a separation wall portion (color conversion portions and transparent resin portions) of the organic EL display device of Variation 12. FIG. 33(b) is a schematic plan view of a layout of light emission regions and a reflection film of the organic EL display device of Variation 12.

[FIG. 34] FIG. 34 is a schematic plan view of a layout of the color light emission control regions, the separation wall portion (color conversion portions and transparent resin portions), and the reflection film of the organic EL display device of Variation 12.

[FIG. 35] FIG. 35 is a cross-sectional view in which a separation structure is provided in Variation 12.

[FIG. 36] FIG. 36 is a cross-sectional view of an organic EL display device according to Variation 13.

[FIG. 37] FIG. 37(a) is a schematic plan view of a layout of color light emission control regions and a separation wall portion (color conversion portions and transparent resin portions) of the organic EL display device of Variation 13. FIG. 37(b) is a schematic plan view of a layout of light emission regions and reflection films of the organic EL display device of Variation 13.

[FIG. 38] FIG. 38 is a schematic plan view of a layout of the color light emission control regions, the separation wall portion (color conversion portions and transparent resin portions), and the reflection films of the organic EL display device of Variation 13.

[FIG. 39] FIG. 39 is a cross-sectional view of an organic EL display device according to a third embodiment.

[FIG. 40] FIG. 40 is a cross-sectional view of an organic EL display device according to a variation of the third embodiment.

[FIG. 41] FIG. 41 is a cross-sectional view of an organic EL display device according to a fourth embodiment.

[FIG. 42] FIG. 42 is a cross-sectional view of an organic EL display device according to Variation 14.

[FIG. 43] FIG. 43 is a cross-sectional view of an organic EL display device according to Variation 15.

[FIG. 44] FIG. 44 is a cross-sectional view of an example bottom emission type organic EL display device in the conventional art.

[FIG. 45] FIG. 45 is a cross-sectional view of an example top emission type organic EL display device in the conventional art.

DESCRIPTION OF EMBODIMENTS

Embodiments of the present invention will be described below by way of example with reference to the accompanying drawings.

<<First Embodiment>>

Firstly, an organic EL display device **100** according to a first embodiment will be described.

<Configuration of Organic EL Display Device **100**>

Firstly, a configuration of the organic EL display device **100** will be described. The organic EL display device **100** is a display which displays an RGB full color image on both front and back sides thereof. The organic EL display device **100** is used, for example, as a display including a single display panel which serves as both a primary screen (main display) and a secondary screen (sub-display), in a mobile device (e.g., a mobile telephone, a multimedia player, etc.) which has a primary screen (main display) and a secondary screen (sub-display), or a display (e.g., an advertising display panel etc.) which displays an image on both front and back sides thereof.

FIGS. **1** and **2** are diagrams schematically showing an overall configuration of the organic EL display device **100**. The organic EL display device **100** includes a flat plate-like organic EL substrate **110** and sealing substrate **120** which face each other. The organic EL display device **100** also has a display region D which is provided at a center of the substrate as viewed from above and is used to display an image, and a frame-like non-display region F which is provided at an outer circumferential portion of the substrates, surrounding the display region D. The organic EL substrate **110** and the sealing substrate **120** are bonded together using a sealing resin **130** in the non-display region F, with the sealed space being filled with an inert atmosphere. A polarizing plate may be provided on each of outer surfaces of the organic EL substrate **110** and the sealing substrate **120**. The organic EL display device **100** has, for example, a length of 400-500 mm, a width of 300-400 mm, and a thickness of 1-30 mm.

FIGS. **3** and **4** are an enlarged plan view and a cross-sectional view, respectively, of the display region D of the organic EL display device **100**. The organic EL display device **100** has, in the display region D, a plurality of red light emission regions P_R , green light emission regions P_G , and blue light emission regions P_B . A predetermined image is displayed in the entire display region D by the light emission regions P_R , P_G , and P_B being driven independently of each other. The light emission regions P_R , P_G , and P_B each have, for example, a length of about 200 μ m and a width of about 50 μ m. The light emission regions P_R , P_G , and P_B are arranged in a matrix, for example, with a spacing of about 100 μ m in the length direction and a space of about 50 μ m in the width direction between each light emission region. A grid-like region other than the light emission regions P_R , P_G , and P_B is a non-light emission region N.

—Organic EL Substrate **110**—

The organic EL substrate **110** includes, on an organic EL substrate body **111**, a plurality of TFTs **112** each provided as a switching element for a corresponding one of the light emission regions P_R , P_G , and P_B , an insulating layer **113** which covers the organic EL substrate body **111** and the TFTs **112**, a plurality of red light emission organic EL elements **115_R**, green light emission organic EL elements **115_G**, and blue light emission organic EL elements **115_B** formed on the insulating layer **113**, corresponding to the red light emission regions P_R , the green light emission regions P_G , and the blue light emission regions P_B , and a separation wall portion **116** formed in a grid-like pattern, corresponding to the non-light emission region N, to separate the organic EL elements **115_R**, **115_G**, and **115_B** from each other. Note that, in the description that follows and the drawings, the red light emission organic EL elements **115_R**, the green light emission organic EL elements **115_G**, and the blue light emission organic EL elements **115_B** may also be collectively referred to as organic EL elements **115**.

—Organic EL Substrate Body **111**—

The organic EL substrate body **111** is, for example, an insulating substrate of glass etc. and has, for example, a length of about 320 mm, a width of about 400 mm, and a thickness of about 0.7 mm.

—Insulating Layer **113**—

As shown in FIG. **4**, the insulating layer **113** includes an interlayer insulating film **113a** (first insulating film) closer to the organic EL substrate body **111**, and a planarization film **113b** (second insulating film) thereabove, which are provided one on top of the other. The interlayer insulating film **113a** includes a first interlayer insulating film **113aa**, a second interlayer insulating film **113ab**, and a third interlayer insulating film **113ac** which are provided on top of one another (see FIG. **6**). The films included in the insulating layer **113** are each formed of, for example, an insulating film of a transparent material (e.g., silicon nitride etc.), or of a transparent insulating resin (e.g., a photosensitive acrylic resin etc.). The films (the interlayer insulating film **113a**, the planarization film **113b**, etc.) included in the insulating layer **113** are each preferably formed of a material having the same refractive index. As a result, when light travels through an interface between each film, the light is not refracted, and therefore, the loss of the light can be reduced or prevented.

A plurality of reflection films **114** are provided between the interlayer insulating film **113a** and the planarization film **113b**, corresponding to the non-light emission region N.

—TFT **112** and Interlayer Insulating Film **113a**—

As shown in FIGS. **5** and **6**, the TFT **112** includes a semiconductor layer **112a**, a gate electrode **112b**, a source electrode **112c**, and a drain electrode **112d**. The semiconductor layer **112a** and the gate electrode **112b** are insulated from each other by the first interlayer insulating film **113aa**. The gate electrode **112b**, and the source electrode **112c** and the drain electrode **112d**, are insulated from each other by the second interlayer insulating film **113ab**. The third interlayer insulating film **113ac** provided above the first interlayer insulating film **113aa**, the second interlayer insulating film **113ab**, and the TFTs **112** is provided so that the entire interlayer insulating film **113a** has a flat surface. The interlayer insulating film **113a** has a thickness of, for example, about 2 μ m.

—Reflection Film **114**—

The reflection films **114** are formed between the interlayer insulating film **113a** and the planarization film **113b**, corresponding to the non-light emission region N. The reflection films **114** are disposed to reflect toward the sealing substrate a portion of light generated in each organic EL layer which is

diffused in a diagonal direction into the non-light emission region N so that the portion of the light is transmitted through the separation wall portion and the sealing substrate to be viewable as an image on the sealing substrate (see FIG. 4). The reflection films 114 are formed of, for example, a light reflective metal film (an Al film etc.). The reflection films 114 each have a thickness of, for example, about 100 nm.

As shown in FIG. 7, the reflection films 114 are formed in an island-like pattern, each corresponding to one of the light emission regions P_R , P_G , and P_B . The reflection films 114 each overlap a circumferential portion of the corresponding one of the light emission regions P_R , P_G , and P_B . If the reflection films 114 do not overlap the light emission regions P_R , P_G , and P_B , external light leaks from gaps between the light emission regions P_R , P_G , and P_B and the reflection films 114 and is viewed on the opposite side of the panel, likely leading to a decrease in display quality. Such a problem does not arise, because the reflection films 114 overlap the circumferential portions of the light emission regions P_R , P_G , and P_B . In addition, because the reflection films 114 overlap the circumferential portions of the light emission regions P_R , P_G , and P_B , the problem that the areas of the light emission regions P_R , P_G , and P_B significantly decrease and therefore the luminance of image display on the organic EL substrate decreases, does not arise. The overlap between the reflection film 114 and the light emission region P_R , P_G , or P_B preferably has a width of about 5-10 μm .

—Planarization Film 113b—

The planarization film 113b is provided on an entire surface of the substrate, covering the interlayer insulating film 113a and the reflection films 114. Because the planarization film 113b is provided to cover the reflection films 114, the insulating layer 113 can have a flat surface without unevenness which would otherwise be caused by the reflection films 114. The planarization film 113b has a thickness of, for example, about 2 μm .

—Organic EL Element 115—

The organic EL element 115 includes a lower electrode 115a, an organic EL layer 115b, and an upper electrode 115c which are successively formed on top of one another (the lower electrode 115a is the closest to the organic EL substrate body 111). Note that, in the red light emission organic EL element 115_R, a red light emission organic EL layer 115b_R is provided as the organic EL layer 115b. In the green light emission organic EL element 115_G, a green light emission organic EL layer 115b_G is provided as the organic EL layer 115b. In the blue light emission organic EL element 115_B, a blue light emission organic EL layer 115b_B is provided as the organic EL layer 115b. Note that, in the description that follows and the drawings, the red light emission organic EL layer 115b_R, the green light emission organic EL layer 115b_G, and the blue light emission organic EL layer 115b_B may also be collectively referred to as the organic EL layers 115b.

Specifically, the organic EL layer 115b includes a hole transporting layer, a light emitting layer, and an electron injection layer which are successively formed on top of one another (the hole transporting layer is the closest to the lower electrode 115a). When a voltage is applied between the lower electrode 115a and the upper electrode 115c, holes are injected from the lower electrode 115a through the hole transporting layer into the light emitting layer, while electrons are injected from the upper electrode 115c through the electron injection layer into the light emitting layer. The holes and electrons recombine in the light emitting layer to emit light.

—Lower Electrode 115a—

The lower electrode 115a is preferably formed of a material having a high work function. Examples of such a material

include metal films of gold (Au), nickel (Ni), platinum (Pt), etc., transparent conductive films of indium oxide-tin oxide alloy (ITO), indium oxide-zinc oxide alloy ($\text{In}_2\text{O}_3\text{—ZnO}$), zinc oxide (ZnO), etc., etc. The lower electrode 115a has a thickness of, for example, about 100 nm. The lower electrode 115a is electrically connected to the drain electrode 112d so that a potential is applied thereto from the TFT 112.

—Organic EL Layer 115b—

The hole transporting layer, the light emitting layer, and the electron injection layer may be formed of materials which are commonly used in the art. Specifically, examples of the material for the hole transporting layer include porphyrin derivatives, aromatic tertiary amine compounds, styryl amine derivatives, polyvinylcarbazole, poly-P-phenylene vinylene, polysilane, triazole derivatives, oxadiazole derivatives, imidazole derivatives, polyaryllkane derivatives, pyrazoline derivatives, pyrazolone derivatives, fluorenone derivatives, hydrogenated amorphous silicon, hydrogenated amorphous silicon carbide, zinc sulfide, and zinc selenide. Examples of the material for the light emitting layer include metal oxinoid compounds (8-hydroxyquinoline metal complexes), naphthalene derivatives, anthracene derivatives, diphenylethylene derivatives, vinylacetone derivatives, triphenylamine derivatives, butadiene derivatives, coumarin derivatives, benzoxazole derivatives, oxadiazole derivatives, oxazole derivatives, benzimidazole derivatives, thiaziazole derivatives, perylene derivatives, perinone derivatives, rodamine derivatives, phenoxazone, quinacridone derivatives, rubrene, poly-P-phenylene vinylene, polysilane, etc. Examples of the material for the electron injection layer include tris(8-hydroxyquinoline) aluminum, oxadiazole derivatives, triazole derivatives, phenylquinoxaline derivatives, silole derivatives, etc.

Note that the light emitting layer of the organic EL layer 115b of the organic EL element 115 in the red light emission region P_R is a red light emitting layer which contains a red light emission material. The light emitting layer of the organic EL layer 115b of the organic EL element 115 in the green light emission region P_G is a green light emitting layer which contains a green light emission material. The light emitting layer of the organic EL layer 115b of the organic EL element 115 in the blue light emission region P_B is a blue light emitting layer which contains a blue light emission material. The organic EL layer 115b needs to include at least a light emitting layer, and may include any other layers that are suitably selected, depending on the purpose of the product. As layers other than the light emitting layer, a hole injection layer, an electron transporting layer, an electron blocking layer, etc. may be optionally provided on top of one another in addition to the hole transporting layer and the electron injection layer.

—Upper Electrode 115c—

The upper electrodes 115c each cover the corresponding one of the organic EL layers 115b. Examples of a material for the upper electrode 115c include materials having a low work function, such as metal materials (e.g., silver (Ag), aluminum (Al), vanadium (V), cobalt (Co), nickel (Ni), tungsten (W), gold (Au), calcium (Ca), titanium (Ti), yttrium (Y), sodium (Na), ruthenium (Ru), manganese (Mn), indium (In), magnesium (Mg), lithium (Li), ytterbium (Yb), etc.), alloys (e.g., lithium fluoride (LiF)/calcium (Ca)/aluminum (Al), etc.), etc. A predetermined common potential is applied to the upper electrodes 115c. Note that interconnects (not shown) for the upper electrodes may be provided on the organic EL substrate body 111, and through holes (not shown) which reach the upper electrode interconnects may be provided in the separation wall portion 116, whereby the common potential can be applied to the upper electrodes 115c. Alternatively, a transparent conductive paste or a transparent conductive film may

be provided on the bonding surface of the sealing substrate **120** to be in contact with the upper electrodes **115c**. In the non-display region F, a common potential interconnect may be connected to the transparent conductive member. As a result, the common potential can be applied to the upper electrodes **115c**.

—Separation Wall Portion **116**—

The separation wall portion **116** is provided in a grid-like pattern, corresponding to the non-light emission region N, to separate the light emission regions P_R , P_G , and P_B from each other. The separation wall portion **116** provided in the non-light emission region N insulates the organic EL elements **115** from each other. The separation wall portion **116** is formed of, for example, a light transmissive insulating material, such as silicon dioxide (SiO_2), silicon nitride film (SiN_x), silicon oxide film (SiO_x), silicon oxynitride film (SiNO), acrylic resin, polyimide resin, etc. The separation wall portion **116** has a grid width of, for example, about $50\ \mu\text{m}$. The separation wall portion **116** has a height of, for example, about $10\ \mu\text{m}$.

The separation wall portion **116** also functions as a spacer which is in contact with and supports the sealing substrate **120**. As a result, another spacer is not required in addition to the separation wall portion **116**, and therefore, the aperture ratio of the organic EL display device **100** can be increased. The top surface of the separation wall portion **116** is not covered by the upper electrodes **115c**, and the separation wall portion **116** itself is in contact with the sealing substrate. Therefore, the sealing substrate **120** can be supported while a distance between the organic EL substrate **110** and the sealing substrate **120** can be maintained constant.

Although FIG. 4 shows that the separation wall portion **116** has a wall surface perpendicular to the organic EL substrate body **111**, as shown in FIG. 8 the separation wall portion **116** may have a forward taper shape which protrudes with the width becoming gradually narrower. Alternatively, as shown in FIG. 9, the separation wall portion **116** may have a backward taper shape which protrudes with the width becoming gradually wider.

Note that when, as shown in FIG. 8, the separation wall portion **116** has the forward taper shape, light which is reflected by the reflection films **114** and then travels toward the sealing substrate **120** is likely to be reflected by the wall surface of the separation wall portion **116** and then travel back toward the organic EL substrate body **111** (see an arrow in FIG. 8). In this case, the efficiency of extraction of light from the sealing substrate **120** decreases, and therefore, it is preferable that the separation wall portion **116** should not have the forward taper shape. When, as shown in FIG. 9, the separation wall portion **116** has the backward taper shape, the upper electrode **115c** is likely to fail to be formed on the wall surface of the separation wall portion **116**. Therefore, in this case, a portion of light passing through the separation wall portion **116** is not reflected by the wall surface and passes through the wall surface in a diagonal direction (see a solid line arrow in FIG. 9; note that a dashed line arrow indicates light reflected by the wall surface of the separation wall portion **116**), and therefore, a displayed image is likely to become cloudy. Therefore, it is preferable that the separation wall portion **116** should not have a backward taper shape which has such a large taper angle that the upper electrode cannot be formed on the wall surface.

—Sealing Substrate **120**—

The sealing substrate **120** includes a glass substrate etc.

<Method for Manufacturing Organic EL Display Device **100**>

Next, a method for manufacturing the organic EL display device **100** of the first embodiment will be described with

reference to FIGS. 10 and 11. The manufacturing method of the organic EL display device **100** includes an organic EL substrate forming step followed by a substrate bonding step.

(Organic EL Substrate Forming Step)

—TFT **112** and Interlayer Insulating Film **113a**—

Initially, the organic EL substrate body **111** is prepared. The semiconductor layer **112a**, the first interlayer insulating film **113aa**, the gate electrode **112b**, the second interlayer insulating film **113ab**, the source electrode **112c**, and the drain electrode **112d** are formed using known techniques to form each of the TFTs **112** corresponding to the light emission regions P_R , P_G , and P_B (the TFTs **112** are not shown in FIG. 10; see FIG. 6). Thereafter, for example, a photosensitive acrylic film is applied by spin coating etc., and then exposed (e.g., the exposure amount is about $360\ \text{mJ}/\text{cm}^2$) and developed (e.g., development with an alkaline developer), to form the third interlayer insulating film **113ac**. As a result, a surface of the TFT **112** is planarized, and the interlayer insulating film **113a** is formed. The interlayer insulating film **113a** is cured by baking under conditions that, for example, the baking temperature is about $220^\circ\ \text{C}$. and the baking time is about one hour, and thereafter, a contact hole (e.g., a diameter of about $5\ \mu\text{m}$) extending from a surface of the interlayer insulating film **113a** to the drain electrode **112d** is formed.

—Reflection Film **114**—

Next, an Al film etc. is formed by, for example, sputtering etc., and then exposed and developed by photolithography, and then patterned, to form the reflection films **114** corresponding to the non-light emission region N.

—Planarization Film **113b**—

Next, for example, a photosensitive acrylic film is applied by spin coating etc., and then exposed and developed, to form the planarization film **113b** as shown FIG. 10(a). The planarization film **113b** is cured by baking under conditions that, for example, the baking temperature is about $220^\circ\ \text{C}$. and the baking time is about one hour. Thereafter, a contact hole is formed at the same position as that of the contact hole provided in the interlayer insulating film **113a**. The resulting contact hole is a contact hole **113c** which extends from a surface of the planarization film **113b** to the drain electrode **112d** (see FIG. 6).

—Lower Electrode **115a**—

Next, an ITO film is formed by, for example, sputtering etc., and then exposed and developed by photolithography, and then patterned, to form the lower electrodes **115a**.

—Separation Wall Portion **116**—

Next, a permanent resist (e.g., “SU-8” series manufactured by Nippon Kayaku Co., Ltd., etc.) is formed on the entire surface by a film laminating process or a spin coat applying process, and then exposed and developed by photolithography, and patterned by etching into a grid-like pattern corresponding to the non-light emission region N, to form the separation wall portion **116**.

—Organic EL Layer **115b**—

Next, as shown in FIG. 10(b), the hole transporting layer, the light emitting layer, the electron injection layer, etc. are formed in each of the light emission regions P_R , P_G , and P_B using known techniques to form the organic EL layers **115b**. In this case, the red light emission organic EL layer **115b_R** including the red light emitting layer is formed in the red light emission region P_R , the green light emission organic EL layer **115b_G** including the green light emitting layer is formed in the green light emission region P_G , and the blue light emission organic EL layer **115b_B** including the blue light emitting layer is formed in the blue light emission region P_B .

—Upper Electrode **115c**—

Next, as shown in FIG. **10(c)**, a metal film, such as an Ag film etc., is formed on the entire surface using a known technique, covering the organic EL layers **115b** and the separation wall portion **116**. Thereafter, the metal film attached to the top of the separation wall portion **116** is removed, for example, using an adhesive roller to form the upper electrodes **115c** corresponding to the light emission regions P_R , P_G , and P_B as shown in FIG. **11(a)**. The organic EL substrate **110** is thus produced.

In addition to the method of using an adhesive roller, the metal film on the separation wall portion **116** is removed, for example, as follows: a method of pressing an adhesive film against the top surface of the separation wall portion **116**; a method of pressing a substrate on which a substance highly reactive to the metal film is applied, against the top surface of the separation wall portion **116**, and allowing the substance to react with the metal film, thereby vaporizing the metal film or causing the metal film to be transparent; a method of scraping the top surface of the separation wall portion **116** while removing chips by suction; etc.

Note that, in addition to the method of forming the upper electrodes **115c** by removing the metal film formed on the entire surface from the separation wall portion **116**, the upper electrodes **115c** may be formed by forming a metal film only in the desired region using an opening mask.

(Substrate Bonding Step)

Finally, in an inert gas atmosphere, the organic EL substrate **110** and the sealing substrate **120** are disposed to face each other, and bonded together using a sealing resin for bonding which is applied in a frame-like region of the substrate. As shown in FIG. **11(b)**, the organic EL display device **100** is thus produced.

<Operation of Organic EL Display Device **100**>

In the organic EL display device **100** thus configured, the reflection films **114** corresponding to the non-light emission region **N** are formed between the interlayer insulating film **113a** and the planarization film **113b** (see FIG. **4**). The reflection films **114** are disposed to reflect toward the sealing substrate **120** a portion of light generated in each organic EL layer **115b** which is diffused into the non-light emission region **N** so that the portion of the light is transmitted through the separation wall portion **116** and the sealing substrate **120** to be viewable as an image on the sealing substrate. Therefore, while light generated in the organic EL layers **115b** is propagated toward the organic EL substrate body **111** to be viewed as an image on the organic EL substrate, a portion of light which is propagated toward the organic EL substrate body **111** and is diffused in a diagonal direction into the non-light emission region **N** is reflected by the reflection films **114** to enter the separation wall portion **116**. The upper electrodes **115c** are provided to cover the respective corresponding organic EL layers **115b**, while the top surface of the separation wall portion **116** is not covered by the upper electrodes **115c**. Therefore, light entering the separation wall portion **116** is transmitted through the separation wall portion **116** without being blocked to enter the sealing substrate **120**, and therefore, is viewed from the outside as an image on the sealing substrate. In other words, by driving a single panel, an image can be displayed on both sides thereof, i.e., the organic EL substrate and the sealing substrate.

Note that, in this case, the organic EL substrate and the sealing substrate of the organic EL display device **100** display mirror images. In other words, an image on the organic EL substrate and an image on the sealing substrate are mirror-symmetrical to each other.

<Advantages of First Embodiment>

Advantages of the organic EL display device **100** of the first embodiment will be described below.

In the organic EL display device **100** of this embodiment, an image displayed on the sealing substrate is formed using light which is emitted in a diagonal direction from the organic EL elements **115**. In an organic EL display device having a conventional configuration, light emitted in a diagonal direction from the organic EL elements is confined between the substrates, and absorbed and thermally deactivated by component materials, or emitted from the end facets of the substrates, and therefore, is not effectively used. However, in this embodiment, the light emitted in a diagonal direction is used to display an image on the sealing substrate, and therefore, even when double-sided display is performed, the light emission luminance of display on the organic EL substrate is not likely to significantly decrease, and the power consumption is not likely to increase. In addition, the reflection films **114** are provided, corresponding to the non-light emission region **N**, to reflect toward the sealing substrate **120** light emitted in a diagonal direction from the organic EL elements **115**. Therefore, it is not likely that the light emission regions P_R , P_G , and P_B are blocked by the reflection films **114** and therefore the display luminance of the organic EL substrate significantly decreases.

Also, in this case, light is transmitted through the separation wall portion **116** corresponding to the non-light emission region **N** to be emitted to the sealing substrate **120** and is therefore viewed as an image on the sealing substrate. Therefore, the large region surrounding the light emission regions P_R , P_G , and P_B can be used as a pixel region of display on the sealing substrate to display an image. Light of the light emission regions P_R , P_G , and P_B is reflected by the reflection films **114** and blended together in the separation wall portion **116** before being displayed on the sealing substrate. Therefore, the boundary between each pixel region in an image displayed on the sealing substrate **120** is less viewable. Therefore, an image can be displayed with high display quality on the sealing substrate **120** as well.

Therefore, the organic EL display device **100** can display an image on both the organic EL substrate and the sealing substrate without an increase in power consumption and with high display quality.

In the organic EL display device **100** of this embodiment, the planarization film **113b** is provided to cover the reflection films **114**, and has a flat surface (i.e., the surface of the insulating layer **113** is flat). Therefore, variations in thickness between the organic EL elements **115** including the lower electrode **115a**, the organic EL layer **115b**, and the upper electrode **115c** formed on the insulating layer **113** are reduced or prevented, whereby the organic EL elements **115** have high reliability.

Moreover, in the organic EL display device **100** of this embodiment, when light generated in the organic EL layer **115b** travels toward the organic EL substrate body **111**, the light is propagated through the insulating layer **113** to enter the organic EL substrate body **111**, or is reflected by the reflection films **114** to enter and pass through the separation wall portion **116** directly to the sealing substrate **120**. Therefore, the light does not travel in a gas, and therefore, the loss of the light can be reduced or prevented.

In conventional top emission type organic EL display devices which display an image on the sealing substrate, the lower electrode is formed of a light reflective material and the upper electrode is formed of a light semi-transmissive material, and therefore, light is unavoidably multiply reflected between the lower and upper electrodes, leading to the prob-

lem that, due to the influence of interference of the light, the color purity or luminance may vary depending on the viewing angle (microcavity effect). However, in the organic EL display device **100** of this embodiment, even though image display is performed on the sealing substrate, the upper electrode **115c** is formed of a light reflective material and the lower electrode **115a** is formed of a light transmissive material, and therefore, it is not necessary to take the influence of the microcavity effect into consideration. Therefore, the problem that the color purity or luminance varies depending on the viewing angle due to the microcavity effect, does not arise.

<Variations of First Embodiment>

Variations 1-7 of the arrangement of the reflection films **114** included in the organic EL display device **100** of the first embodiment will be described.

(Variations 1-5)

In the first embodiment, as described with reference to FIG. 7, the reflection films **114** are each formed, corresponding to one of the light emission regions P_R , P_G , and P_B . The layout of the reflection films **114** is not limited to this. Alternatively, for example, each reflection film **114** may be provided, corresponding to a plurality of light emission regions P_R , P_G , and P_B .

Specifically, as shown in FIG. 12 as Variation 1, each reflection film **114** may be provided, extending along a plurality of light emission regions having the same color. When each reflection film **114** is provided, extending along a plurality of light emission regions having the same color, as shown in FIGS. 13 and 14 as Variation 2 each reflection film **114** may be provided, overlapping circumferential portions of both adjacent light emission regions having different colors (i.e., the red light emission regions P_R and the green light emission regions P_G , the green light emission regions P_G and the blue light emission regions P_B , or the blue light emission regions P_B and the red light emission regions P_R). Alternatively, as shown in FIG. 15 as Variation 3, each reflection film **114** may be provided, extending in a direction perpendicular to the direction along which a plurality of light emission regions having the same color are arranged.

As shown in FIG. 16 as Variation 4, each reflection film **114** may be provided, surrounding the corresponding one of the light emission regions P_R , P_G , and P_B . In this case, as shown in FIG. 17 as Variation 5, a reflection film **114** may be provided, surrounding every one of the light emission regions P_R , P_G , and P_B and corresponding to the entire non-light emission region N.

Note that the amount of light reflected toward the back side can be adjusted by changing the area of the reflection films **114**. For example, Variation 1 is compared with Variation 2 in which the area of the reflection films **114** is larger. In Variation 1, light is reflected toward the sealing substrate by the reflection film **114** provided on the right side of each of the light emission regions P_R , P_G , and P_B (see FIG. 4). In Variation 2, light is reflected toward the sealing substrate by the reflection films **114** provided both the right and left sides of each of the light emission regions P_R , P_G , and P_B (see FIG. 14). Therefore, on the sealing substrate **120**, display having a higher luminance can be provided in Variation 2 in which the area of the reflection films **114** is larger, than in Variation 1.

(Variation 6)

In the first embodiment and Variations 1-5, the light emission regions P_R , P_G , and P_B and the reflection films **114** overlap. Alternatively, as shown in FIG. 18 as Variation 6, the light emission regions P_R , P_G , and P_B and the reflection film **114** may not overlap.

(Variation 7)

In the first embodiment and Variations 1-6, the reflection films **114** have the same layout with respect to the light emission regions P_R , P_G , and P_B . Alternatively, the reflection films **114** may have different layouts corresponding to characteristics of the respective organic EL elements **115_R**, **115_G**, and **115_B**. For example, as shown in FIG. 19 as Variation 7, the reflection film **114** may have an island-like pattern with respect to the red light emission region P_R and the green light emission region P_G , while the reflection film **114** may have a U shape surrounding the blue light emission region P_B at a portion corresponding to the blue light emission region P_B . In this case, a portion of light which is emitted from the blue light emission region P_B in a diagonal direction toward the non-light emission region N, can be more efficiently reflected toward the back side than light which is emitted from the red light emission region P_R and the green light emission region P_G . It is known that, of organic EL light emission materials, blue light emission materials have a lower light emission efficiency and a shorter light emission life than those of red light emission materials and green light emission materials. Therefore, by arranging the reflection films **114** as shown in FIG. 19, blue light can be more effectively used, whereby the current density of the blue light emission region P_B can be reduced and therefore the light emission life of the blue light emission region P_B can be increased. Note that the amount of light emitted from the blue light emission region P_B toward the organic EL substrate can be adjusted by providing a light emission area different from those of the other colors.

Note that, in the first embodiment, the organic EL display device **100** displays an RGB full color image on both sides thereof. Alternatively, for example, a yellow light emission region may be provided as an additional light emission region to display an RGBY full color image. Alternatively, a monochromatic image may be displayed.

<<Second Embodiment>>

Next, an organic EL display device **200** according to the second embodiment will be described.

<Configuration of Organic EL Display Device 200>

Firstly, a configuration of the organic EL display device **200** will be described. The organic EL display device **200** is a display which displays an image on both front and back sides thereof, where a monochromatic image is displayed on one of the sides (a side on which an organic EL substrate **210** is provided) and an RGB full color image is displayed on the other side (a side on which a sealing substrate **220** is provided). The organic EL display device **200** is used, for example, as a display including a single display panel which serves as both a primary screen (main display) and a secondary screen (sub-display), in a mobile device (e.g., a mobile telephone, a multimedia player, etc.) having a primary screen (main display) and a secondary screen (sub-display), or a display (e.g., an advertisement display panel etc.) which displays an image on both front and back sides thereof.

As in the first embodiment, the organic EL display device **200** includes the flat panel-like organic EL substrate **210** and sealing substrate **220** which face each other. The sealing substrate **220** has a configuration similar to that of the sealing substrate **120** of the first embodiment.

FIG. 20 is a cross-sectional view of a display region D of the organic EL display device **200**. The organic EL display device **200** includes a plurality of blue light emission regions P_B arranged in a matrix. A predetermined image is displayed in the entire display region D by the blue light emission regions P_B being driven independently of each other.

Note that one third of the blue light emission regions P_B are red light emission control regions Q_R which are pixels which

emit red light and are used to display a full color image on the sealing substrate **220**. Similarly, one third of the blue light emission regions P_B are green light emission control regions Q_G which emit green light and are used to display a full color image on the sealing substrate **220**. One third of the blue light emission regions P_B are blue light emission control region Q_B which emit blue light and are used to display a full color image on the sealing substrate **220**. A grid-like region other than the blue light emission regions P_B is a non-light emission region **N**.

—Organic EL Substrate **210**—

The organic EL substrate **210** includes, on an organic EL substrate body **211**, a plurality of TFTs (not shown) each provided as a switching element for a corresponding one of the blue light emission regions P_B , an insulating layer **213** which covers the organic EL substrate body **211** and the TFTs, a plurality of blue light emission organic EL elements **215_B** provided on the insulating layer **213**, corresponding to the blue light emission regions P_B , and a separation wall portion **216** formed in a grid-like pattern, corresponding to the non-light emission region **N**, to separate the blue light emission organic EL elements **215_B** from each other. The insulating layer **213** includes an interlayer insulating film **213a** (first insulating film) closer to the organic EL substrate body **211**, and a planarization film **213b** (second insulating film) thereabove, which are provided one on top of the other. A plurality of reflection films **214** are provided between the interlayer insulating film **213a** and the planarization film **213b**, corresponding to the non-light emission region **N**. The organic EL substrate body **211**, the TFT, the insulating layer **213**, and the blue light emission organic EL element **215_B** have configurations similar to those of the organic EL display device **100** of the first embodiment.

—Separation Wall Portion **216**—

The separation wall portion **216** is provided in a grid-like pattern, corresponding to the non-light emission region **N**, to separate the blue light emission regions P_B from each other. The separation wall portion **216** provided in the non-light emission region **N** insulates the organic EL elements **215** from each other.

The separation wall portion **216** also functions as a spacer which is in contact with and supports the sealing substrate **220**. As a result, another spacer is not required in addition to the separation wall portion **216**, and therefore, the aperture ratio of the organic EL display device **200** can be increased. The top surface of the separation wall portion **216** is not covered by upper electrodes **215c**, and the separation wall portion **216** itself is in contact with the sealing substrate. Therefore, the sealing substrate **220** can be supported while a distance between the organic EL substrate **210** and the sealing substrate **220** can be maintained constant.

The separation wall portion **216** includes red conversion portions **216_R**, green conversion portions **216_G**, and transparent resin portions **216_S**. The red conversion portion **216_R** has a function of converting the wavelength of blue light transmitted therethrough (Stokes shift) and thereby extracting light having a red wavelength. The red conversion portion **216_R** is formed of a transparent resin (e.g., an acrylic resin etc.) doped with a fluorescent material (e.g., a silicate-based fluorescent material manufactured by Nemoto & Co., Ltd., etc.). The green conversion portion **216_G** has a function of converting the wavelength of blue light transmitted therethrough and thereby extracting light having a green wavelength. The green conversion portion **216_G** is formed of a transparent resin (e.g., an acrylic resin etc.) doped with a fluorescent material (e.g., a silicate-based fluorescent material manufactured by Nemoto & Co., Ltd., etc.). The transparent resin portion **216_S**

does not convert the wavelength of blue light transmitted through the separation wall portion **216**. The transparent resin portion **216_S** is formed of a transparent resin (e.g., an acrylic resin etc.), similar to the separation wall portion **116** of the first embodiment.

The red conversion portions **216_R**, the green conversion portions **216_G**, and the transparent resin portions **216_S** are arranged as shown in FIG. **21(a)**. Specifically, the red conversion portion **216_R** is a band-like portion of the separation wall portion **216** which is provided on the right side of the red light emission control regions Q_R arranged in the length direction. The green conversion portion **216_G** is a band-like portion of the separation wall portion **216** which is provided on the right side of the green light emission control regions Q_G arranged in the length direction. The transparent resin portion **216_S** is a portion of the separation wall portion **216** which excludes the red conversion portion **216_R** and the green conversion portion **216_G**.

Here, as shown in FIG. **21(b)**, the reflection films **214** are formed in an island-like pattern, corresponding to the blue light emission regions P_B (the red conversion portions **216_R**, the green conversion portions **216_G**, and the transparent resin portions **216_S**). The reflection films **214** are disposed so that a portion of blue light generated in the red light emission control regions Q_R which is diffused in a diagonal direction into the non-light emission region **N** is reflected by the reflection films **214** toward the sealing substrate **220** to enter the red conversion portions **216_R** of the separation wall portion **216**. The reflection films **214** are also disposed so that a portion of blue light generated in the green light emission control regions Q_G which is diffused in a diagonal direction into the non-light emission region **N** is reflected by the reflection films **214** toward the sealing substrate **220** to enter the green conversion portions **216_G** of the separation wall portion **216**. The reflection films **214** are also disposed so that a portion of blue light generated in the blue light emission control region Q_B which is diffused in a diagonal direction into the non-light emission region **N** is reflected by the reflection films **214** toward the sealing substrate **220** to enter the transparent resin portions **216_S** of the separation wall portion **216**.

The color conversion portions **216_R** and **216_G** and the transparent resin portions **216_S** preferably have the same height. In this case, the separation wall portion **216** can function as a spacer for supporting the sealing substrate **220** at the color conversion portions **216_R** and **216_G** and the transparent resin portions **216_S**.

Note that, for example, in order to adjust the efficiency of color conversion of the color conversion portions **216_R** and **216_G**, the heights of the color conversion portions **216_R** and **216_G** can be suitably changed as long as they are lower than the height of the transparent resin portions **216_S**. In this case, only the transparent resin portions **216_S** of the separation wall portion **216** function as a spacer for supporting the sealing substrate **220**. Note that the color conversion efficiency etc. may be adjusted, for example, when the thickness of the color conversion portion is increased in order to improve the color purity or when the thickness of the color conversion portion is decreased in order to obtain red light and green light having a high luminance.

The transparent resin portions **216_S** and the color conversion portions **216_R** and **216_G** may overlap at a portion which is a boundary therebetween. In this case, the separation wall portion **216** has a largest height at the overlap region, and therefore, is in contact with and supports the sealing substrate **220** at the overlap region.

<Method for Manufacturing Organic EL Display Device 200>

Next, a method for manufacturing the organic EL display device 200 will be described. The manufacturing method of the organic EL display device 200 includes an organic EL substrate forming step followed by a substrate bonding step.

(Organic EL Substrate Forming Step)

—TFT-Lower Electrode 215a—

As in the first embodiment, the TFTs, the interlayer insulating film 213a, the reflection films 214, the planarization film 213b, and the lower electrodes 215a are formed on the organic EL substrate body 211.

—Separation Wall Portion 216—

Next, a permanent resist is formed on the entire surface by a film laminating process or a spin coat applying process, and then exposed and developed by photolithography, and etched, to form the transparent resin portions 216s. Similarly, the red conversion portions 216r and the green conversion portions 216g are formed. Note that the red conversion portion 216r, the green conversion portion 216g, and the transparent resin portion 216s may be formed in any sequence.

—Organic EL Layer 215b—

Next, the hole transporting layer, the blue light emitting layer, the electron injection layer, etc. are formed using known techniques, corresponding to each of the blue light emission regions P_B, to form a blue organic EL layer 215b. In this case, the blue light emitting layer containing a blue light emission material may be formed in all light emission regions as light emitting layers. Therefore, the organic EL layers 215b can be easily formed.

—Upper Electrode 215c—

After the formation of the organic EL layers 215b, the upper electrodes 215c are formed on the organic EL layers 215b in a manner similar to that of the first embodiment.

(Substrate Bonding Step)

Finally, the organic EL substrate 210 and the sealing substrate 220 thus obtained are bonded together to obtain the organic EL display device 200.

<Operation of Organic EL Display Device 200>

In the organic EL display device 200, all the light emission regions are the blue light emission region P_B, and all the organic EL elements 215 are the blue organic EL element 215b. Therefore, light generated in the blue light emission organic EL layers 215b is propagated to the organic EL substrate body 211 to be viewed as a monochromatic blue image on the organic EL substrate.

On the other hand, a portion of light generated in each blue light emission organic EL layer 215b which is diffused in a diagonal direction into the non-light emission region N is reflected toward the sealing substrate 220 by the corresponding reflection film 214 formed between the interlayer insulating film 213a and the planarization film 213b. The light reflected by the reflection films 214 travels through the separation wall portion 216 to be viewed as an image on the sealing substrate. In this case, the way in which the light travels will be described in detail for each of the light emission control regions Q_R, Q_G, and Q_B.

As shown in FIGS. 21 and 22, the reflection films 214 are disposed so that a portion of blue light generated in the red light emission control regions Q_R which is diffused in a diagonal direction into the non-light emission region N is reflected by the reflection films 214 toward the sealing substrate 220 to enter the red conversion portions 216r of the separation wall portion 216. Therefore, blue light generated in the red light emission control regions Q_R is converted into red light when the blue light is transmitted through the red conversion portions 216r. The resulting light is viewed as red light included

in an image on the sealing substrate. Similarly, blue light generated in the green light emission control regions Q_G is converted into green light when the blue light is transmitted through the green conversion portions 216g. The resulting light is viewed as green light included in an image on the sealing substrate. Blue light generated in the blue light emission control region Q_B is transmitted through the transparent resin portions 216s to be viewed as blue light included in an image on the sealing substrate. Therefore, on the sealing substrate 220, blue light obtained in the red light emission control regions Q_R is viewed as red light, blue light obtained in the green light emission control regions Q_G is viewed as green light, and blue light generated in the blue light emission control regions Q_B is viewed as blue light.

Here, the principle that blue light generated in the red light emission control region Q_R enters the red conversion portion 216r, blue light generated in the green light emission control region Q_G enters the green conversion portion 216g, and blue light generated in the blue light emission control region Q_B enters the transparent resin portion 216s, will be described.

Referring to FIG. 22, in order to allow blue light generated in the red light emission control region Q_R to be reflected by the reflection film 214 and then enter the red conversion portion 216r, the blue light from the red light emission control region Q_R needs to be reflected by the reflection film 214 provided on the right side of the red light emission control region Q_R. In other words, while blue light generated in the blue light emission organic EL layer 215b of the red light emission control region Q_R travels toward the organic EL substrate body 211, and at the same time, is equally diffused in a diagonal right direction and a diagonal left direction, it is necessary to cause the light diffused in a diagonal left direction to reach the reflection film 214 but not to reach the sealing substrate 220, or to reach the reflection film 214 but not to be reflected toward the sealing substrate 220. On the other hand, it is necessary to cause the light diffused in a diagonal right direction to reach the reflection film 214 and then be reflected toward the sealing substrate 220.

On the right side of the red light emission control region Q_R, the reflection film 214(R) is disposed to overlap a circumferential portion of the red light emission control region Q_R. Therefore, as shown in FIG. 23(a), light diffused in a diagonal right direction with respect to the red light emission control region Q_R is reflected by the reflection film 214(R) to enter the red conversion portion 216r.

On the other hand, on the left side of the red light emission control region Q_R, the red light emission control region Q_R and the reflection film 214(L) do not overlap and are separated from each other by a predetermined distance as viewed from above (note that, in FIG. 23, the distance between the reflection film 214(L) and the red light emission control region Q_R is exaggerated (i.e., not to scale)). Therefore, as shown in FIG. 23(a), light diffused in a diagonal left direction with respect to the red light emission control region Q_R is reflected by the reflection film 214(L) at a larger reflection angle than when light is reflected by the reflection film 214(R) on the right side. The larger reflection angle causes the reflected light to have a lower luminance (Lambertian distribution). As shown in FIG. 23(b), the large reflection angle of light reflected by the reflection film 214(L) may cause the light reflected by the reflection film 214(L) to fail to enter the separation wall portion 216 (the transparent resin portion 216s). As shown in FIG. 23(c), even when light reflected by the reflection film 214(L) successfully enters the separation wall portion 216, the large incident angle to the separation wall portion 216 causes the light to be totally reflected by an interface between the separation wall portion 216 and the

sealing substrate **220** or to be totally reflected by an interface between the sealing substrate **220** and the outside air, and therefore, the light reflected by the reflection film **214(L)** is not viewed on the sealing substrate.

Therefore, blue light generated in the red light emission control region Q_R is allowed to enter the red conversion portion **216_R**, blue light generated in the green light emission control region Q_G is allowed to enter the green conversion portion **216_G**, and blue light generated in the blue light emission control region Q_B is allowed to enter the transparent resin portion **216_S**.

Thus, in the organic EL display device **200**, a monochromatic blue image is viewed on the organic EL substrate, while an RGB full color image is viewed on the sealing substrate.

<Advantages of Second Embodiment>

Advantages of the organic EL display device **200** of the second embodiment will be described below.

In the organic EL display device **200** of this embodiment, an image displayed on the sealing substrate is formed using light emitted in a diagonal direction from the organic EL elements **215**. Therefore, similar to the organic EL display device **100** of the first embodiment, light emitted in a diagonal direction is used to form an image on the sealing substrate. Therefore, even when double-sided display is performed, the luminance of display on the organic EL substrate is not likely to significantly decrease, and the power consumption is not likely to increase. It is also not likely that the blue light emission regions P_B are blocked by the reflection films **214** and therefore the luminance of display on the organic EL substrate significantly decreases.

In this case, an image is viewed on the sealing substrate because light is emitted through the separation wall portion **216** corresponding to the non-light emission region **N** toward the sealing substrate **220**. Therefore, similar to the organic EL display device **100** of the first embodiment, an image can be displayed with high display quality on the sealing substrate **220** as well.

Therefore, in the organic EL display device **200**, both the monochromatic blue image on the organic EL substrate and the RGB full color image on the sealing substrate can be displayed with high display quality and without an increase in power consumption.

Similar to the organic EL display device **100** of the first embodiment, the organic EL display device **200** of the second embodiment has the following advantages in addition to the above advantage.

In the organic EL display device **200**, the planarization film **213b** having a flat surface is provided to cover the reflection films **214**, and therefore, it is easy to control the thickness of each of the organic EL elements **215**, resulting in the highly reliable organic EL elements **215**. In the organic EL display device **200**, similar to the organic EL display device **100** of the first embodiment, light does not travel in a gas, and therefore, the loss of the light can be reduced or prevented. In the organic EL display device **200**, even though an image is displayed on the sealing substrate, the problem that the color purity or luminance varies depending on the viewing angle due to the microcavity effect, does not arise.

In addition to the advantages of the organic EL display device **100** of the first embodiment, advantages specific to the organic EL display device **200** are as follows.

In the organic EL display device **200**, all the light emission regions are the blue light emission region P_B , and therefore, only the blue light emitting layers need to be formed as the light emitting layers. Therefore, the organic EL display device **200** can be more easily fabricated, leading to a higher yield.

In the organic EL display device **200**, red light and green light are obtained by the red conversion portion **216_R** and the green conversion portion **216_G**. Therefore, the red light and the green light can be caused to have a desired chromaticity by adjusting a thickness or color conversion characteristics of the fluorescent material of the color conversion portions **216_R** and **216_G**, respectively.

<Variations of Second Embodiment>

Variations of the separation wall portion **216**, the reflection film **214**, etc. included in the organic EL display device **200** of the second embodiment will be described below.

(Variation 8)

FIG. **24** shows a cross-sectional view of the organic EL display device **200** according to Variation 8. FIG. **25** shows a schematic layout of the color light emission control regions Q_R , Q_G , and Q_B , the separation wall portion **216**, and the reflection films **214**. Here, in the separation wall portion **216**, portions which convert blue light into light having a red wavelength are provided as red conversion portions **216_{RS}** which are provided by forming the red conversion portions **216_R** on the transparent resin portions **216_S**. Also, portions which convert blue emitted light into light having a green wavelength are provided as green conversion portions **216_{GS}** which are provided by forming the green conversion portions **216_G** on the transparent resin portions **216_S**.

Even when the heights of the color conversion portions **216_R** and **216_G** are caused to be smaller than that of the transparent resin portion **216_S** in order to adjust the tinge of red light and green light extracted from the sealing substrate **220**, in the configuration of Variation 8 the smaller heights of the color conversion portions **216_R** and **216_G** are compensated for by the transparent resin portion **216_S**, whereby the separation wall portion **216** can have a uniform height in the entire region. Therefore, the function of the separation wall portion **216** as a spacer has higher reliability.

(Variation 9)

FIGS. **26** and **27** show a schematic layout of the color light emission control regions Q_R , Q_G , and Q_B , the separation wall portion **216**, and the reflection films **214** of the organic EL display device **200** according to Variation 9.

In the second embodiment, the red conversion portions **216_R** and the green conversion portions **216_G** are provided in a band-like pattern on the right sides of the red light emission control regions Q_R and the green light emission control regions Q_G , and the transparent resin portions **216_S** are provided in regions above and below the red light emission control regions Q_R and the green light emission control regions Q_G . Alternatively, as shown in FIG. **26(a)**, the red conversion portions **216_R** may also be provided in regions above and below the red light emission control regions Q_R , and the green conversion portions **216_G** may also be provided in regions above and below the green light emission control regions Q_G .

In this case, as shown in FIG. **26(b)**, the reflection film **214** is also provided in regions above and below the color light emission control regions Q_R , Q_G , and Q_B , whereby a portion of blue light generated in the red light emission control regions Q_R which leaks in a diagonal direction is reflected toward the sealing substrate **220** by the reflection film **214** on three sides (the right, upper, and lower sides) of the red light emission control regions Q_R . The reflected light travels through the red conversion portions **216_R** before reaching the sealing substrate **220**, so that the light having a blue wavelength is converted into light having a red wavelength. As a result, a red image is obtained on the sealing substrate **220**. This holds true for blue light generated in the green light emission control regions Q_G and the blue light emission con-

control regions Q_B . Therefore, in addition to light leaking rightward with respect to the color light emission control regions Q_R , Q_G , and Q_B , light leaking in diagonal up and down directions with respect to the color light emission control regions Q_R , Q_G , and Q_B can be effectively used as an image on the sealing substrate **220**, whereby the efficiency of light emission on the sealing substrate **220** can be increased.

(Variations 10 and 11)

FIGS. **28** and **29** schematically show a layout of the color light emission control regions Q_R , Q_G , and Q_B , the separation wall portion **216**, and the reflection films **214** of the organic EL display device **200** according to Variation 10. FIGS. **30** and **31** schematically show a layout of the color light emission control regions Q_R , Q_G , and Q_B , the separation wall portion **216**, and the reflection films **214** of the organic EL display device **200** according to Variation 11.

As shown in FIG. **28(a)** as Variation 10, the color conversion portions and the transparent resin portions **216_S** of the separation wall portion **216** may be arranged as follows: the red conversion portions **216_R** are provided on the right sides and either the upper sides or the lower sides of the red light emission control regions Q_R ; the green conversion portions **216_G** are provided on the right sides and either the upper sides or the lower sides of the green light emission control regions Q_G ; and the transparent resin portions **216_S** are provided on the right sides and either the upper sides or the lower sides of the blue light emission control regions Q_B . Alternatively, as shown in FIG. **30(a)** as Variation 11, the red conversion portions **216_R** may be provided on the right sides of the red light emission control regions Q_R , the transparent resin portions **216_S** may be provided on the upper and lower sides of the red light emission control regions Q_R , the green conversion portions **216_G** may be provided on the right sides of the green light emission control regions Q_G , the red conversion portions **216_R** may be provided on the upper and lower sides of the green light emission control regions Q_G , and the transparent resin portions **216_S** may be provided on the right sides of the blue light emission control regions Q_B .

In Variation 10, light leaking in two directions (rightward and upward, or rightward and downward) with respect to the color light emission control regions Q_R , Q_G , and Q_B is reflected by the reflection films **214** toward the sealing substrate **220**. In Variation 11, light leaking in a diagonal right direction with respect to the color light emission control regions Q_R , Q_G , and Q_B is reflected by the reflection films **214** toward the sealing substrate **220**. Note that Variation 9 is more preferable in terms of the efficiency of light emission on the sealing substrate **220**.

(Variation 12)

FIG. **32** shows a cross-sectional view of the organic EL display device **200** according to Variation 12. FIGS. **33** and **34** schematically show a layout of the color light emission control regions Q_R , Q_G , and Q_B , the separation wall portion **216**, and the reflection films **214** of the organic EL display device **200** of Variation 12.

As shown in FIG. **33(a)**, in the separation wall portion **216** of Variation 12, the red conversion portion **216_R** is provided between each red light emission control region Q_R , the green conversion portion **216_G** is provided between each green light emission control region Q_G , and the transparent resin portion **216_S** is provided between each blue light emission control region Q_B . A region between the red light emission control region Q_R and the green light emission control region Q_G is divided into two in a direction along the edges of the light emission control regions Q_R and Q_G . The red conversion

portion **216_R** is provided in the portion closer to the red light emission control region Q_R , while the green conversion portion **216_G** is provided in the portion closer to the green light emission control region Q_G . A region between the green light emission control region Q_G and the blue light emission control region Q_B is divided into two in a direction along the edges of the light emission control regions Q_G and Q_B . The green conversion portion **216_G** is provided in the region closer to the green light emission control region Q_G , while the transparent resin portion **216_S** is provided in the portion closer to the blue light emission control region Q_B . A region between the blue light emission control region Q_B and the red light emission control region Q_R is divided into two in a direction along the edges of the light emission control regions Q_B and Q_R . The transparent resin portion **216_S** is provided in the portion closer to the blue light emission control region Q_B , while the red conversion portion **216_R** is provided in the portion closer to the red light emission control region Q_R .

As shown in FIG. **33(b)**, the reflection films **214** are provided to surround the color light emission control regions Q_R , Q_G , and Q_B , and overlap the color light emission control regions Q_R , Q_G , and Q_B .

This configuration allows a portion of blue light generated in the red light emission control regions Q_R which leaks in a diagonal direction, to be reflected by the reflection films **214** no matter whether the light leaks in rightward, leftward, upward, or downward with respect to the control regions. The reflected light travels through the red conversion portions **216_R** provided around the red light emission control regions Q_R before reaching the sealing substrate **220**, whereby light having a blue wavelength is converted into light having a red wavelength, and therefore, a red image is obtained on the sealing substrate **220**. This holds true for blue light generated in the green light emission control regions Q_G and the blue light emission control regions Q_B . Therefore, light leaking in all diagonal right, left, up, and down directions from the color light emission control regions Q_R , Q_G , and Q_B can be effectively used as an image on the sealing substrate **220**, whereby the efficiency of light emission on the sealing substrate **220** can be increased.

Note that, as shown in FIG. **35**, in order to reduce or prevent mixture of the colors, a separation structure **216h** may be provided at a boundary between the color conversion portion **216_R** or **216_G** and the transparent resin portion **216_S** of the control regions having the different colors. The separation structure **216h** may be formed by providing, in the step of forming the separation wall portion **216**, a gap at a boundary portion between the red conversion portion **216_R** and the green conversion portion **216_G**, at a boundary portion between the red conversion portion **216_R** and the transparent resin portion **216_S**, and at a boundary portion between the green conversion portion **216_G** and the transparent resin portion **216_S**. This is because, in the subsequent step of forming the upper electrode **215c**, these gaps are filled with the upper electrode material, whereby the separation structure **216h** is formed.

(Variation 13)

FIG. **36** shows a cross-sectional view of the organic EL display device **200** according to Variation 13. FIGS. **37** and **38** schematically show a layout of the color light emission control regions Q_R , Q_G , and Q_B , the separation wall portion **216**, and the reflection films **214** of the organic EL display device **200** of Variation 13.

In Variation 13, the blue light emission regions P_B include the red light emission control regions Q_R , the green light emission control regions Q_G , and the blue light emission control regions Q_B . As shown in FIGS. **36-38**, each single

blue light emission region P_B includes the red light emission control region Q_R and the green light emission control region Q_G , the green light emission control region Q_G and the blue light emission control region Q_B , or the blue light emission control region Q_B and the red light emission control region Q_R . In other words, one blue light emission region P_B is driven by two independent switching elements. Of the blue light emission region P_B , a region adjacent to the red conversion portion **216_R** of the separation wall portion **216** is disposed to serve as the red light emission control region Q_R , a region adjacent to the green conversion portion **216_G** is disposed to serve as the green light emission control region Q_G , and a region adjacent to the transparent resin portion **216_S** is disposed to serve as the blue light emission control region Q_B .

As shown in FIG. 37(b), the reflection films **214** are provided to overlap left and right circumferential portions of the blue light emission regions P_B .

With this configuration, in the blue light emission region P_B including the red light emission control region Q_R and the green light emission control region Q_G , blue light leaking in a diagonal direction from the red light emission control region Q_R is reflected by the reflection film **214** toward the sealing substrate **220** to enter the red conversion portion **216_R**, so that the light is viewed as red light on the sealing substrate. On the other hand, blue light leaking in a diagonal direction from the green light emission control region Q_G is reflected by the reflection film **214** toward the sealing substrate **220** to enter the green conversion portion **216_G**, so that the light is viewed as green light on the sealing substrate. This holds true for the blue light emission region P_B including the green light emission control region Q_G and the blue light emission control region Q_B , and the blue light emission region P_B including the blue light emission control region Q_B and the red light emission control region Q_R .

In the second embodiment, a monochromatic blue image is displayed on the organic EL substrate of the organic EL display device **200**. Alternatively, a monochromatic image having a color other than blue may be displayed by, for example, allowing light to be viewed through a color conversion filter.

<<Third Embodiment>>

Next, an organic EL display device **300** according to a third embodiment will be described.

<Configuration of Organic EL Display Device **300**>

Firstly, a configuration of the organic EL display device **300** will be described. The organic EL display device **300** is a display which displays an RGB full color image on both front and back sides thereof. The organic EL display device **300** is used, for example, as a display including a single display panel which serves as both a primary screen (main display) and a secondary screen (sub-display), in a mobile device (a mobile telephone, a multimedia player, etc.) which has a primary screen (main display) and a secondary screen (sub-display), or a display (an advertising display panel etc.) which displays an image on both front and back sides thereof.

As in the first embodiment, the organic EL display device **300** includes a flat panel-like organic EL substrate **310** and sealing substrate **320** which face each other. The sealing substrate **320** has a configuration similar to that of the sealing substrate **120** of the first embodiment.

FIG. 39 is a cross-sectional view of a display region D of the organic EL display device **300**. The organic EL display device **300** has, in the display region D, a plurality of red light emission regions P_R , green light emission regions P_G , and blue light emission regions P_B which are arranged in a matrix. A predetermined image is displayed in the entire display region D by the light emission regions P_R , P_G , and P_B being

driven independently of each other. A grid-like region other than the blue light emission regions P_R , P_G , and P_B is a non-light emission region N.

—Organic EL Substrate **310**—

The organic EL substrate **310** includes, on an organic EL substrate body **311**, a plurality of TFTs each provided as a switching element for a corresponding one of the light emission regions P_R , P_G , and P_B , an insulating layer **313** which covers the organic EL substrate body **311** and the TFTs, a plurality of red light emission organic EL elements **315_R**, green light emission organic EL elements **315_G**, and blue light emission organic EL elements **315_B** provided on the insulating layer **313**, corresponding to the red light emission regions P_R , the green light emission regions P_G , and the blue light emission regions P_B , and a separation wall portion **316** formed in a grid-like pattern, corresponding to the non-light emission region N, to separate the organic EL elements **315_R**, **315_G**, and **315_B** from each other. Note that, in the description that follows and the drawings, the red light emission organic EL elements **315_R**, the green light emission organic EL elements **315_G**, and the blue light emission organic EL elements **315_B** may also be collectively referred to as organic EL elements **315**. The organic EL substrate body **311**, the TFTs, the insulating layer **313**, the organic EL elements **315**, and the separation wall portion **316** have configurations similar to those of the organic EL display device **100** of the first embodiment.

—Insulating Layer **313**—

As shown in FIG. 39, the insulating layer **313** includes an interlayer insulating film **313a** (first insulating film) closer to the organic EL substrate body **311**, and a planarization film **313b** (second insulating film) thereabove, which are provided one on top of the other. A plurality of reflection films **314** are provided between the interlayer insulating film **313a** and the planarization film **313b**, corresponding to the non-light emission region N.

—Interlayer Insulating Film **313a**—

Similar to the organic EL display device **100** of the first embodiment, the interlayer insulating film **313a** includes a first interlayer insulating film, a second interlayer insulating film, and a third interlayer insulating film which are provided on top of one another. A plurality of recessed portions **314ca** are formed on a surface of the interlayer insulating film **313a**, corresponding to regions in which the reflection films **314** are provided. The recessed portions **314ca** will be described along with the reflection films **314**.

—Reflection Film **314**—

Similar to the reflection films **114** of the organic EL display device **100** of the first embodiment, the reflection films **314** are formed between the interlayer insulating film **313a** and the planarization film **313b**, corresponding to the non-light emission region N. The reflection films **314** are disposed to reflect toward the sealing substrate a portion of light generated in each organic EL layer **315b** which is diffused in a diagonal direction into the non-light emission region N so that the light is transmitted through the separation wall portion **316** and the sealing substrate **320** to be viewed as an image on the sealing substrate. The reflection films **314** are formed in an island-like pattern, each corresponding to one of the light emission regions P_R , P_G , and P_B .

A plurality of recessed portions **314c** are formed on surfaces of the reflection films **314**, corresponding to the recessed portions **314ca** provided on the surface of the interlayer insulating film **313a**. The recessed portions **314c** each have, for example, a circular shape whose cross-section has a diameter of about 10 μm and a depth of about 1 μm . The recessed portions **314c** are arranged with a spacing of about 5

μm between each recessed portion. Note that the recessed portions **314c** each have a cross-section having, for example, a rectangular shape, in addition to the circular shape.

Note that the surface of the reflection film **314** may be caused to be uneven by providing a plurality of recessed portions on the surface of the reflection film **314**. Alternatively, for example, the surface of the reflection film **314** may be caused to be uneven by providing a plurality of grooves which are arranged side by side, extending in the length and width directions.

—Planarization Film **313b**—

The planarization film **313b** is provided on the entire surface of the substrate, covering the interlayer insulating film **313a** and the reflection films **314**. Because the planarization film **313b** is provided to cover the reflection films **314**, the insulating layer **313** can have a flat surface without unevenness which would otherwise be caused by the reflection films **314**.

<Method for Manufacturing Organic EL Display Device **300**>

Next, a method for manufacturing the organic EL display device **300** will be described. The manufacturing method of the organic EL display device **300** includes an organic EL substrate forming step followed by a substrate bonding step.

(Organic EL Substrate Forming Step)

—TFT and Interlayer Insulating Film **313a**—

The TFTs and the interlayer insulating film **313a** are formed on the organic EL substrate body **311** in a manner similar to that of the first embodiment. The recessed portions **314ca** are formed by halftone exposure, corresponding to regions of the interlayer insulating film **313a** in which the reflection films **314** are to be formed.

—Reflection Film **314**—

Next, an Al film etc. is formed by, for example, sputtering etc., and then exposed and developed by photolithography, and patterned by etching, to form the reflection films **314** corresponding to the non-light emission region N. In this case, the recessed portions **314c** are formed on the surface of the reflection film **314**, corresponding to the recessed portions **314ca** formed on the interlayer insulating film **313a**.

—Planarization Film **313b**—

Next, for example, a photosensitive acrylic film is applied by spin coating etc., and then exposed and developed, to form the planarization film **313b** having a flat surface.

—Lower Electrode **315a**-Upper Electrode **315c**—

The steps of forming, on the planarization film **313b**, the lower electrodes **315a**, the separation wall portion **316**, the organic EL layers **315b**, and the upper electrodes **315c** are similar to those of the first embodiment.

(Substrate Bonding Step)

Finally, the organic EL substrate **310** and the sealing substrate **320** thus obtained are bonded together to obtain the organic EL display device **300**.

Note that, in the step of forming the recessed portions **314ca** on the interlayer insulating film **313a**, the recessed portions **314ca** may be formed in other regions in addition to the regions in which the reflection films **314** are to be formed. For example, as shown in FIG. **40**, a plurality of recessed portions **314ca** may be formed on an entire surface of the interlayer insulating film **313a**. As a result, a simpler exposure pattern can be used to form the recessed portions **314ca** by halftone exposure. When the interlayer insulating film **313a** and the planarization film **313b** are each formed of a material having the same refractive index, then even if a plurality of recessed portions **314ca** are formed on an entire surface of the interlayer insulating film **313a**, the planarization film **313b** is formed to cover the interlayer insulating film **313a**, and there-

fore, the loss of light does not occur at an interface between the interlayer insulating film **313a** and the planarization film **313b**, and therefore, display characteristics of the organic EL display device **300** are not affected.

<Operation of Organic EL Display Device **300**>

In the organic EL display device **300**, the reflection films **314** are formed between the interlayer insulating film **313a** and the planarization film **313b**, corresponding to the non-light emission region N. The reflection films **314** are disposed to efficiently reflect toward the sealing substrate **320** a portion of light generated in each organic EL layer **315b** which is diffused into the non-light emission region N so that the portion of the light is transmitted through the separation wall portion **316** and the sealing substrate **320** to be viewable as an image on the sealing substrate. Therefore, while light generated in the organic EL layers **315b** is propagated toward the organic EL substrate body **311** to be viewed as an image on the organic EL substrate, a portion of light which is propagated toward the organic EL substrate body **311** and is diffused in a diagonal direction into the non-light emission region N is reflected by the reflection films **314** to enter the separation wall portion **316**. In this case, because the recessed portions **314c** are formed on the surface of the reflection films **314**, light is diffused and reflected by the reflection films **314** to enter the separation wall portion **316**. Thereafter, the light entering the separation wall portion **316** is transmitted through the separation wall portion **316** without being blocked to enter the sealing substrate **320**, and therefore, is viewed from the outside as an image on the sealing substrate. In other words, by driving a single panel, an image can be displayed on both sides thereof, i.e., the organic EL substrate and the sealing substrate.

<Advantages of Third Embodiment>

Advantages of the organic EL display device **300** will be described below.

In the organic EL display device **300** of this embodiment, an image displayed on the sealing substrate is formed using light which is emitted in a diagonal direction from the organic EL elements **315**. Therefore, similar to the organic EL display device **100** of the first embodiment, the light emitted in a diagonal direction is used to display an image on the sealing substrate, and therefore, even when double-sided display is performed, the light emission luminance of display on the organic EL substrate is not likely to significantly decrease, and the power consumption is not likely to increase. In addition, it is not likely that the light emission regions P_R , P_G , and P_B are blocked by the reflection films **314** and therefore the display luminance of the organic EL substrate significantly decreases.

In this case, light is transmitted through the separation wall portion **316** corresponding to the non-light emission region N to the sealing substrate **320** to be viewed as an image on the sealing substrate. Therefore, similar to the organic EL display device **100** of the first embodiment, an image can be displayed with high display quality on the sealing substrate **320** as well.

Therefore, in the organic EL display device **300**, an image can be displayed on both the organic EL substrate and the sealing substrate with high display quality and without an increase in power consumption.

Similar to the organic EL display device **100** of the first embodiment, the organic EL display device **300** of the second embodiment has the following advantages in addition to the above advantage.

In the organic EL display device **300**, similar to the organic EL display device **100** of the first embodiment, light does not travel in a gas, and therefore, the loss of the light can be reduced or prevented. In the organic EL display device **300**,

even though an image is displayed on the sealing substrate, the problem that the color purity or luminance varies depending on the viewing angle due to the microcavity effect, does not arise.

In addition to the advantages of the organic EL display device **100** of the first embodiment, advantages peculiar to the organic EL display device **300** are as follows.

In the organic EL display device **300**, the recessed portions **314c** are provided on the surfaces of the reflection films **314**. Therefore, when a portion of light generated in each organic EL layer **315b** which is emitted in a diagonal direction is reflected by the corresponding reflection film **314**, the light is reflected toward the sealing substrate **320** while being scattered by the recessed portions **314c**. If the reflection film has a flat surface, light traveling toward the reflection film is reflected at a reflection angle which is equal to the incident angle. In this case, the reflected light contains many components traveling in a diagonal direction with respect to the substrate. Light reflected by the reflection film **314** is scattered by the recessed portions **314c**, and therefore, contains many components traveling in a front direction with respect to the substrate. Therefore, the recessed portions **314c** formed on the reflection film **314** provide more excellent viewing angle characteristics of display on the sealing substrate.

Even when the recessed portions **314c** are formed on the reflection films **314** of the organic EL display device **300**, the planarization film **313b** is provided to cover the interlayer insulating film **313a** and the reflection films **314**, and has a flat surface. Therefore, it is easy to control the thickness of each of the organic EL elements **315**, resulting in the highly reliable organic EL elements **315**.

<<Fourth Embodiment>>

Firstly, an organic EL display device **400** according to a fourth embodiment will be described.

<Configuration of Organic EL Display Device **400**>

Firstly, a configuration of the organic EL display device **400** will be described. The organic EL display device **400** is a display which displays an RGB full color image on both front and back sides thereof. The organic EL display device **400** is used, for example, as a display including a single display panel which serves as both a primary screen (main display) and a secondary screen (sub-display), in a mobile device (a mobile telephone, a multimedia player, etc.) which has a primary screen (main display) and a secondary screen (sub-display), or a display (an advertising display panel etc.) which displays an image on both front and back sides thereof.

As in the first embodiment, the organic EL display device **400** includes a flat panel-like organic EL substrate **410** and sealing substrate **420** which face each other.

FIG. **41** is a cross-sectional view of a display region D of the organic EL display device **400**. The organic EL display device **400** includes a plurality of red light emission regions P_R , green light emission regions P_G , and blue light emission regions P_B . A predetermined image is displayed in the entire display region D by the light emission regions P_R , P_G , and P_B being driven independently of each other. A grid-like region other than the light emission regions P_R , P_G , and P_B is a non-light emission region N.

—Organic EL Substrate **410**—

The organic EL substrate **410** includes, on an organic EL substrate body **411**, a plurality of TFTs each provided as a switching element for a corresponding one of the light emission regions P_R , P_G , and P_B , an insulating layer **413** which covers the organic EL substrate body **411** and the TFTs, a plurality of red light emission organic EL elements **415_R**, green light emission organic EL elements **415_G**, and blue light emission organic EL elements **415_B** provided on the

insulating layer **413**, corresponding to the red light emission regions P_R , the green light emission regions P_G , and the blue light emission regions P_B , and a separation wall portion **416** formed in a grid-like pattern, corresponding to the non-light emission region N, to separate the organic EL elements **415_R**, **415_G**, and **415_B** from each other. Note that, in the description that follows and the drawings, the red light emission organic EL elements **415_R**, the green light emission organic EL elements **415_G**, and the blue light emission organic EL elements **415_B** may also be collectively referred to as organic EL elements **415**. The organic EL substrate body **411**, the TFTs, and the separation wall portion **416** have configurations similar to those of the first embodiment.

—Insulating Layer **413**—

The insulating layer **413** is provided on the organic EL substrate body **411**, covering the organic EL substrate body **411** and the TFTs. The insulating layer **413** is formed of, for example, a transparent insulating resin, such as a photosensitive acrylic resin etc. The insulating layer **413** may be formed of a single film or a plurality of films. The insulating layer **413** is formed to have a flat surface.

—Organic EL Element **415**—

The organic EL element **415** includes a lower electrode **415a**, an organic EL layer **415b**, and an upper electrode **415c** which are successively formed on top of one another (the lower electrode **415a** is the closest to the organic EL substrate body **411**). Note that, in the red light emission organic EL element **415_R**, a red light emission organic EL layer **415b_R** is provided as the organic EL layer **415b**. In the green light emission organic EL element **415_G**, a green light emission organic EL layer **415b_G** is provided as the organic EL layer **415b**. In the blue light emission organic EL element **415_B**, a blue light emission organic EL layer **415b_B** is provided as the organic EL layer **415b**. Note that, in the description that follows and the drawings, the red light emission organic EL layer **415b_R**, the green light emission organic EL layer **415b_G**, and the blue light emission organic EL layer **415b_B** may also be collectively referred to as the organic EL layers **415b**.

Specifically, the organic EL layer **415b** includes a hole transporting layer, a light emitting layer, and an electron injection layer which are successively formed on top of one another (the hole transporting layer is the closest to the upper electrode **415c**). When a voltage is applied between the lower electrode **415a** and the upper electrode **415c**, electrons are injected from the lower electrode **415a** through the electron injection layer into the light emitting layer, while holes are injected from the upper electrode **415c** through the hole transporting layer into the light emitting layer. The electrons and holes recombine in the light emitting layer to emit light.

—Lower Electrode **415a**—

The lower electrode **415a** is preferably formed of a material having a low work function, such as a metal material (e.g., silver (Ag), aluminum (Al), vanadium (V), cobalt (Co), nickel (Ni), tungsten (W), calcium (Ca), titanium (Ti), yttrium (Y), sodium (Na), ruthenium (Ru), manganese (Mn), indium (In), magnesium (Mg), lithium (Li), ytterbium (Yb), etc.), an alloy (e.g., lithium fluoride (LiF)/calcium (Ca)/aluminum (Al), etc.), etc. The lower electrode **415a** is electrically connected to the drain electrode so that a potential is applied thereto from the TFT.

—Organic EL Layer **415b**—

The hole transporting layer, the light emitting layer, and the electron injection layer are each formed of a material similar to that illustrated for the organic EL display device **100** of the first embodiment.

—Upper Electrode **415c**—

The upper electrodes **415c** each cover the correspond one of the organic EL layers **415b**. The upper electrode **415c** is formed of a light transmissive material, such as a material having a high work function (e.g., indium oxide-tin oxide alloy (ITO), indium oxide-zinc oxide alloy ($\text{In}_2\text{O}_3\text{—ZnO}$), zinc oxide (ZnO), etc.), etc. A predetermined common potential is applied to the upper electrodes **415c**.

—Sealing Substrate **420**—

The sealing substrate **420** includes, on a surface closer to the organic EL substrate **410** of a sealing substrate body **421** formed of a glass substrate etc., reflection films **424** corresponding to the non-light emission region N, and an insulating layer **423** covering the sealing substrate body **421** and the reflection films **424**.

—Reflection Film **424**—

The reflection films **424** are formed on the sealing substrate body **421**, corresponding to the non-light emission region N. The reflection films **424** are disposed to reflect toward the organic EL substrate **410** a portion of light generated in each organic EL layer **415b** which is diffused in a diagonal direction into the non-light emission region N so that the light is transmitted through the separation wall portion and the organic EL substrate body to be viewable as an image on the organic EL substrate. The reflection films **424** are formed of, for example, a light reflective metal film (e.g., an Al film etc.) etc. The reflection films **424** each have a thickness of, for example, about 100 nm.

Similar to the reflection films **114** of the first embodiment, the reflection films **424** are formed in an island-like pattern, corresponding to the light emission regions P_R , P_G , and P_B (see FIG. 7).

—Insulating Layer **423**—

The insulating layer **423** is provided on the organic EL substrate body **411**, covering the organic EL substrate body **411** and the reflection films **424**. The insulating layer **423** is formed of, for example, a transparent insulating resin, such as a photosensitive acrylic resin etc. The insulating layer **423** may be formed of a single film or a plurality of films. The insulating layer **423** is formed to have a flat surface.

<Method for Manufacturing Organic EL Display Device **400**>

Next, a method for manufacturing the organic EL display device **400** will be described. The manufacturing method of the organic EL display device **400** includes an organic EL substrate forming step and a sealing substrate forming step followed by a substrate bonding step.

(Organic EL Substrate Forming Step)

—TFT and Insulating Layer **413**—

The TFTs and the insulating layer **413** are formed on the organic EL substrate body **411** in a manner similar to that of the first embodiment.

—Lower Electrode **415a**—Organic EL Layer **415b**—

Next, the lower electrodes **415a** are formed by a known technique. Thereafter, the separation wall portion **416** and the organic EL layers **415b** are formed in a manner similar to that of the first embodiment.

—Upper Electrode **415c**—

Next, an ITO film is formed by a known technique on the entire surface, covering the organic EL layers **415b** and the separation wall portion **416**. Thereafter, the ITO film attached to the top of the separation wall portion **416** is removed, for example, using an adhesive roller to form the upper electrodes **415c** corresponding to the light emission regions P_R , P_G , and P_B . The organic EL substrate **110** is thus produced. Note that an ITO film may be formed only on the desired region using an opening mask to form the upper electrodes **415c**.

(Sealing Substrate Forming Step)

—Reflection Film **424**—

Next, the sealing substrate body **421** is prepared. An Al film etc. is formed on the sealing substrate body **421** by, for example, sputtering etc., and then exposed and developed by photolithography, and patterned by etching, to form the reflection films **424** corresponding to the non-light emission region N.

—Insulating Layer **423**—

Next, for example, a photosensitive acrylic film is applied by spin coating etc., and exposed and developed, to form the insulating layer **423** covering the sealing substrate body **421** and the reflection films **424**. As a result, the sealing substrate **420** is obtained.

(Substrate Bonding Step)

Finally, in an inert gas atmosphere, the organic EL substrate **410** and the sealing substrate **420** are disposed to face each other, and bonded together with a sealing resin for bonding which is applied in a frame-like region of the substrate. In this case, the organic EL substrate **410** and the sealing substrate **420** are accurately positioned so that the light emission regions P_R , P_G , and P_B are not misaligned between the organic EL substrate **410** and the sealing substrate **420**. The organic EL display device **400** is thus produced.

<Operation of Organic EL Display Device **400**>

In the organic EL display device **400**, the upper electrodes **415c** of the organic EL elements **415** are formed of a light transmissive material, and the lower electrodes **415a** are formed of a light reflective material. Therefore, light generated in the organic EL layers **415b** is extracted through the upper electrodes **415c** to be viewed on the sealing substrate. On the other hand, the reflection films **424** are formed on a surface closer to the organic EL substrate **410** of the sealing substrate **420**, corresponding to the non-light emission region N. The reflection films **424** are disposed to reflect toward the organic EL substrate **410** a portion of light generated in each organic EL layer **415b** which is diffused into the non-light emission region N so that the portion of the light is transmitted through the separation wall portion **416** and the organic EL substrate body **411** to be viewed as an image on the organic EL substrate. Therefore, a portion of light generated in each organic EL layer **415b** which is propagated toward the sealing substrate **420** and is diffused in a diagonal direction into the non-light emission region N is reflected by the corresponding reflection film **424** to enter the separation wall portion **416**. The light entering the separation wall portion **416** is transmitted through the separation wall portion **416** without being blocked to enter the organic EL substrate body **411**, and therefore, is viewed from the outside as an image on the organic EL substrate. In other words, by driving a single panel, an image can be displayed on both sides thereof, i.e., the organic EL substrate and the sealing substrate.

<Advantages of Fourth Embodiment>

Advantages of the organic EL display device **400** will be described below.

In the organic EL display device **400** of this embodiment, an image displayed on the organic EL substrate is formed using light which is emitted in a diagonal direction from the organic EL elements **415**. Therefore, as in the first embodiment, even when double-sided display is performed, the light emission luminance of display on the sealing substrate is not likely to significantly decrease, and the power consumption is not likely to increase. In addition, it is not likely that the light emission regions P_R , P_G , and P_B are blocked by the reflection films **424** and therefore the display luminance of the organic EL substrate significantly decreases.

In this case, light is emitted through the separation wall portion **416** corresponding to the non-light emission region N to the organic EL substrate **411** to be viewed as an image on the organic EL substrate. Therefore, similar to the organic EL display device **100** of the first embodiment, an image can be displayed with high display quality on the organic EL substrate **410** as well.

Therefore, in the organic EL display device **400**, an image can be displayed on both the organic EL substrate and the sealing substrate with high display quality and without an increase in power consumption.

In conventional top emission type organic EL display devices which display an image on the sealing substrate, typically, the lower electrode is formed of a light reflective material and the upper electrode is formed of a light semi-transmissive material, and therefore, light is unavoidably multiply reflected between the lower and upper electrodes, leading to the problem that, due to the influence of interference of the light, the color purity or luminance may vary depending on the viewing angle (microcavity effect). Alternatively, the lower electrode may be formed of a light transmissive material and the upper electrode may be formed of a light semi-transmissive material to obtain a double-sided light emitting type organic EL display device. However, irregular luminance is likely to occur due to variations in transmittance or reflectance of the upper electrode. However, in the organic EL display device **400** of this embodiment, the upper electrode **415c** may be formed of a light transmissive material, and it is not necessary to take into consideration the influence of the microcavity effect between the lower electrode **415a** and the upper electrode **415c**. Therefore, the problem that the color purity or luminance varies depending on the viewing angle due to the microcavity effect, does not arise. In addition, the upper electrode **415c** is formed of a light transmissive material, and therefore, irregular luminance which is caused due to variations in transmittance or reflectance does not occur.

<Variations of Fourth Embodiment>

Variations of the organic EL display device **400** of the fourth embodiment will be described below.

(Variation 14)

FIG. **42** shows a cross-sectional view of the organic EL display device **400** according to Variation 14. In this organic EL display device **400**, in addition to the configuration of the fourth embodiment, a space between the organic EL substrate **410** and the sealing substrate **420** is filled with a transparent resin **417**. As a result, when light generated in the organic EL layers **415b** is propagated toward the sealing substrate **420**, the light does not travel in a gas, and therefore, the loss of the light can be reduced or prevented.

The transparent resin **417** is preferably formed of a material having the same refractive index as that of the insulating layer **423**. Such a material is, for example, a solvent-free epoxy resin etc. Note that, in order to reduce or prevent damage to the organic EL elements **415** when the transparent resin **417** is cured by heating or UV light irradiation, a protection film (not shown) is preferably provided to cover the organic EL elements **415**. The protection film is formed of, for example, a transparent insulating film, such as a SiO_x film etc.

(Variation 15)

FIG. **43** shows a cross-sectional view of the organic EL display device **400** according to Variation 15. In this organic EL display device **400**, a plurality of recessed portions **424c** are formed on a surface of each reflection film **424**. As a result, as in the third embodiment, when a portion of light generated in each organic EL layer **415b** which is emitted in a diagonal

direction is reflected by the corresponding reflection film **424**, the light is reflected toward the organic EL substrate **410** while being scattered by the recessed portions **424c**. Therefore, more excellent viewing angle characteristics of display on the sealing substrate are obtained.

Note that the recessed portions **424c** may be formed as follows: a first insulating film **423a** is formed on the sealing substrate body **421**; a plurality of recessed portions **424ca** are formed in regions of a surface of the first insulating film **423a** in which the reflection films **424** are to be formed; and thereafter, the reflection films **424** are formed. By forming a second insulating film **423b** to cover the reflection films **424** on a surface of which the recessed portions **424c** have been formed, the insulating layer **423** is caused to have a flat surface.

INDUSTRIAL APPLICABILITY

The present invention is useful for double-sided display type organic EL display devices which display an image on both sides of a panel thereof, and methods for manufacturing such display devices.

Description of Reference Characters

D DISPLAY REGION

F NON-DISPLAY REGION

P_R RED LIGHT EMISSION REGION

P_G GREEN LIGHT EMISSION REGION

P_B BLUE LIGHT EMISSION REGION

100, 200, 300, 400 ORGANIC EL DISPLAY DEVICE

110, 210, 310, 410 ORGANIC EL SUBSTRATE

111, 211, 310, 411 ORGANIC EL SUBSTRATE BODY

112 TFT (SWITCHING ELEMENT)

113, 213, 313, 413 INSULATING LAYER

113a, 213a, 313a INTERLAYER INSULATING FILM (FIRST INSULATING FILM)

113b, 213b, 313b PLANARIZATION FILM (SECOND INSULATING FILM)

114, 214, 314, 424 REFLECTION FILM

115a, 215a, 315a, 415a LOWER ELECTRODE

115b, 215b, 315b, 415b ORGANIC EL LAYER

115c, 215c, 315c, 415c UPPER ELECTRODE

116, 216, 316, 416 SEPARATION WALL PORTION

120, 220, 320, 420 SEALING SUBSTRATE

216_G GREEN CONVERSION PORTION

216_R RED CONVERSION PORTION

216_S TRANSPARENT RESIN PORTION

314c RECESSED PORTION

417 TRANSPARENT RESIN

The invention claimed is:

1. An organic EL display device comprising an organic EL substrate having a plurality of light emission regions arranged in a matrix, and a sealing substrate, the organic EL substrate and the sealing substrate facing each other, and having a frame-like non-display region provided at a circumferential portion of the substrates, and a display region provided on an inner side of the frame-like non-display region, wherein

the organic EL substrate includes

an organic EL substrate body,

a plurality of switching elements provided on the organic EL substrate body, each corresponding to one of the plurality of light emission regions,

an insulating layer covering the organic EL substrate body and the plurality of switching elements and having a flat surface,

a plurality of lower electrodes of a light transmissive material provided on the insulating layer, each corresponding to one of the plurality of light emission regions,

a separation wall portion of a light transmissive material provided on the insulating layer, corresponding to a region other than the light emission regions, and configured to separate the plurality of light emission regions from each other,

a plurality of organic EL layers each covering a corresponding one of the plurality of lower electrodes, and

an upper electrode of a light reflective material covering the plurality of organic EL layers, and

light generated in the organic EL layers is propagated to the organic EL substrate body to be viewed as an image on the organic EL substrate,

the insulating layer includes a first insulating film and a second insulating film provided thereabove,

there are a plurality of the upper electrodes each covering a corresponding one of the plurality of organic EL layers, and

a reflection film is provided between the first and second insulating films, corresponding to the region other than the light emission regions, and is configured to reflect toward the sealing substrate a portion of light generated in each of the organic EL layers which is diffused into the region other than the light emission regions so that the portion of the light is transmitted through the separation wall portion and the sealing substrate to be viewable as an image on the sealing substrate.

2. The organic EL display device of claim 1, wherein the reflection film overlaps a circumferential portion of each of the light emission regions.

3. The organic EL display device of claim 1, wherein the separation wall portion functions as a spacer which is in contact with and supports the sealing substrate.

4. The organic EL display device of claim 1, wherein the first and second insulating films are each formed of a material having the same refractive index.

5. The organic EL display device of claim 1, wherein the plurality of light emission regions include red light emission regions configured to emit red light, green light emission regions configured to emit green light, and blue light emission regions configured to emit blue light.

6. The organic EL display device of claim 1, wherein the plurality of light emission regions include blue light emission regions,

the separation wall portion includes

a red conversion portion configured to convert blue light transmitted through the separation wall portion into red light,

a green conversion portion configured to convert blue light transmitted through the separation wall portion into green light, and

a transparent resin portion configured not to convert a wavelength of light transmitted through the separation wall portion, and

blue light generated in the organic EL layers is propagated to the organic EL substrate body to be viewed as a monochromatic image on the organic EL substrate, and a portion of the blue light which is diffused into the region other than the light emission regions is reflected by the reflection film toward the sealing substrate, and is then transmitted through the red and green conversion portions and the transparent resin portion to provide red,

green, and blue light, respectively, which are then transmitted through the sealing substrate to be viewed as an RGB full color image on the sealing substrate.

7. The organic EL display device of claim 1, wherein the reflection film has an uneven surface.

8. The organic EL display device of claim 7, wherein the uneven surface is formed by recessed portions provided on the reflection film.

9. A method for manufacturing the organic EL display device of claim 1, the method comprising:

an organic EL substrate forming step of producing the organic EL substrate by

forming the plurality of switching elements on the organic EL substrate body, each corresponding to one of the plurality of light emission regions,

forming the first insulating layer covering the organic EL substrate body and the plurality of switching elements,

forming the reflection film on the first insulating film, corresponding to a region other than the light emission regions,

forming the second insulating film covering the first insulating film and the reflection film and having a flat surface,

forming the plurality of lower electrodes on the second insulating film, each corresponding to one of the plurality of light emission regions,

forming the separation wall portion on the second insulating film, corresponding to the region other than the light emission regions, to separate the plurality of light emission regions from each other,

forming the plurality of organic EL layers each covering a corresponding one of the plurality of lower electrodes, and

forming the plurality of upper electrodes each covering a corresponding one of the plurality of organic EL layers, and

a substrate bonding step of disposing the organic EL substrate produced by the organic EL substrate forming step and the sealing substrate to face each other, and bonding the organic EL substrate and the sealing substrate together at the non-display region,

wherein

in the organic EL substrate forming step, the reflection film is formed so that a portion of light generated in each of the organic EL layers which is diffused into the region other than the light emission regions is reflected by the reflection film, and is then transmitted through the separation wall portion and the sealing substrate to be viewed as an image on the sealing substrate.

10. The method of claim 9, wherein

in the organic EL substrate forming step, the reflection film is formed to overlap a circumferential portion of each of the light emission regions.

11. The method of claim 9, wherein

in the substrate bonding step, the sealing substrate and the organic EL substrate are disposed to face each other so that the separation wall portion is in contact with and supports the sealing substrate.

12. The method of claim 9, wherein

in the organic EL substrate forming step,

after the formation of the first insulating film, a recessed portion is formed on at least a surface of a region in which the reflection film is to be formed, and

after the formation of the recessed portion, the reflection film is formed on top of the recessed portion formed on

43

the surface of the first insulating film, whereby the reflection film having a recessed portion on a surface thereof is formed.

13. The method of claim 12, wherein a plurality of recessed portions are formed on the entire surface of the first insulating film. 5

14. An organic EL display device comprising an organic EL substrate having a plurality of light emission regions arranged in a matrix, and a sealing substrate, the organic EL substrate and the sealing substrate facing each other, and having a frame-like non-display region provided at a circumferential portion of the substrates, and a display region provided on an inner side of the frame-like non-display region, wherein 10

the organic EL substrate includes 15
 an organic EL substrate body,
 a plurality of switching elements provided on the organic EL substrate body, each corresponding to one of the plurality of light emission regions, 20
 an insulating layer covering the organic EL substrate body and the plurality of switching elements and having a flat surface,
 a plurality of lower electrodes of a light reflective material provided on the insulating layer, each corresponding to one of the plurality of light emission regions, 25
 a separation wall portion of a light transmissive material provided on the insulating layer, corresponding to a region other than the light emission regions, 30
 and configured to separate the plurality of light emission regions from each other,

44

a plurality of organic EL layers each covering a corresponding one of the plurality of lower electrodes, and

an upper electrode of a light transmissive material or a light semi-transmissive material covering the plurality of organic EL layers, and

light generated in the organic EL layers is propagated to the sealing substrate to be viewed as an image on the sealing substrate,

there are a plurality of the upper electrodes each covering a corresponding one of the plurality of organic EL layers, and

a reflection film is provided on a surface closer to the organic EL substrate of the sealing substrate, corresponding to the region other than the light emission regions, and is configured to reflect toward the organic EL substrate a portion of light generated in each of the organic EL layers which is diffused into the region other than the light emission regions so that the portion of the light is transmitted through the separation wall portion and the organic EL substrate body to be viewable as an image on the organic EL substrate.

15. The organic EL display device of claim 14, wherein the upper electrode is formed of a light transmissive material.

16. The organic EL display device of claim 14, wherein the reflection film overlaps a circumferential portion of each of the light emission regions.

17. The organic EL display device of claim 14, wherein a space between the organic EL substrate and the sealing substrate is filled with a transparent resin.

* * * * *

专利名称(译)	有机EL显示装置及其制造方法		
公开(公告)号	US8895974	公开(公告)日	2014-11-25
申请号	US13/980310	申请日	2012-01-31
[标]申请(专利权)人(译)	杉本HIROSHI 园田彻		
申请(专利权)人(译)	杉本HIROSHI 园田, 彻		
当前申请(专利权)人(译)	夏普株式会社		
[标]发明人	SUGIMOTO HIROSHI SONODA TOHRU		
发明人	SUGIMOTO, HIROSHI SONODA, TOHRU		
IPC分类号	H01L51/56 H01L21/00 H01L29/08 H01L27/32 H01L51/52		
CPC分类号	H01L51/56 H01L2251/5323 H01L51/5203 H01L27/3258 H01L51/5271		
代理机构(译)	美富律师事务所		
优先权	2011023987 2011-02-07 JP		
其他公开文献	US20130299808A1		
外部链接	Espacenet USPTO		

摘要(译)

在有机EL显示装置(100)中,绝缘层(113)包括设置在其上的第一绝缘膜(113a)和第二绝缘膜(113b),多个上电极(115c)各自设置为覆盖相应的多个有机EL层(115b)中的一个,并且反射膜(114)设置在第一绝缘膜(113a)和第二绝缘膜(113b)之间,对应于除发光区域之外的区域N。反射膜(114)向密封基板(120)反射在每个有机EL层(115b)中产生的光的一部分,该部分光被扩散到除了发光区域之外的区域N中,使得光的一部分透过隔离壁部分(116)和密封基板(120)被视为密封基板上的图像。

